

# Axial Piston Variable Pump ATUS-PVXS

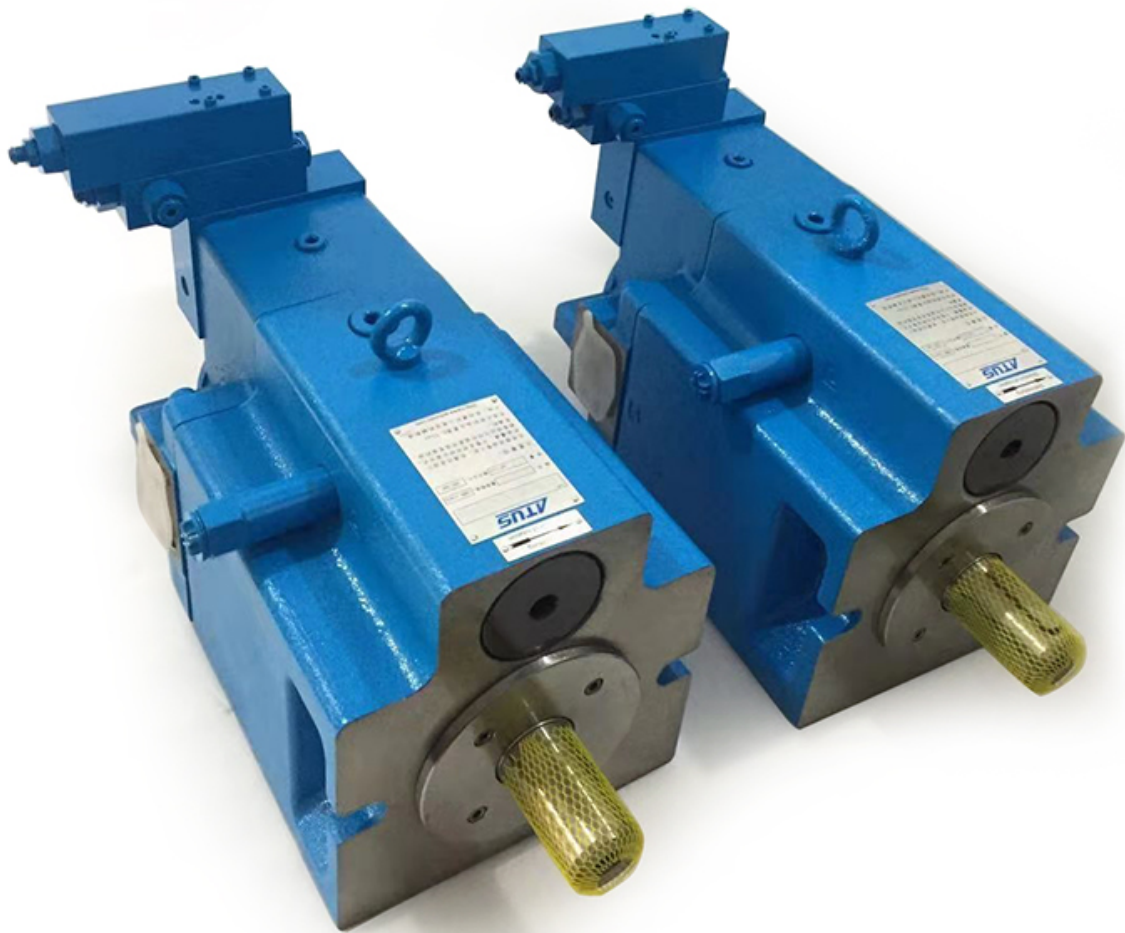

# Table of Contents

Introduction .....	4
Model Code	
Form Page .....	5
Basic Pumps .....	6
No Control .....	7
DF Control.....	8
DQ Control .....	9
LR Control .....	10
ES Control .....	11
HG Control.....	12
FE Control .....	13
DP Control .....	14
SP Control .....	15
Special Features.....	16
Combination Units.....	17
Examples for Combination units .....	18
Pump Specifications	
US .....	19
Metric .....	20
Performance Curves	
Performance Curves, Outlet Flow & Inlet Power, Shaft Input Power, 066 to 250 Series.....	21
Operating Data:Theoretical Bearing Life .....	22
Operating Data:Typical Drain Flow .....	23
Controls	
DF, LR Pressure Compensator/Power Control .....	24
DQ Mooring Control .....	27
FE, HG Manual Displacement Adj. Control .....	28
Electric Motor Displacement Control ES .....	29
Pressure Signal Displacement Control DP.....	30
Proportional Valve Displacement Control SP.....	31

Table of Contents  
(cont.)

Pump Dimensions \*

- ATUS-PFXS 066. . . . . 32
- ATUS-PFXS 090. . . . . 33
- ATUS-PFXS 130. . . . . 34
- ATUS-PFXS 180. . . . . 35
- ATUS-PFXS 250. . . . . 36
- ATUS-PVXS 066 - 250 DF, Two Stage Pilot Valve . . . . . 38
- ATUS-PVXS 066 - 250 DF, with Load Sensing Valve . . . . . 40
- ATUS-PVXS 066 - 250 LR, with Pressure Limiter . . . . . 42
- ATUS-PVXS 066 - 250 ES . . . . . 44
- ATUS-PVXS 066 - 250 DP, with Prop. Pilot Valve. . . . . 46
- ATUS-PVXS 066 - 250 SP, with Prop. Pilot Valve. . . . . 48
- Thru - drives . . . . . 50
- Splined Shaft . . . . . 51
- SAE4 - Bolt Mounting, Installation Data . . . . . 52

Application Data

- Fluid Recommendations . . . . . 53

\* Dimensions - ATUS-PVXS-066 to 250 DQ/HG/FE ask for special drawings.

## Introduction

- Axial piston pumps with swashplate design for reliable operation and long life.
- Pressure up to 420 bar. Rated speed up to 1800 min<sup>-1</sup>. Higher speeds possible.
- Oversize shafts and bearings.
- Rotating and pressure loaded parts are pressure balanced.
- Integrated pilot pump, filter and pressure relief valves available.
- "Building block" design gives these pumps a wide range of application.
- Fast response times.

### AVAILABLE DISPLACEMENT SIZES

66 ccm

90 ccm

130 ccm

180 ccm

### AVAILABLE REPLACEMENT UNIT DISPLACEMENT SIZES

250 ccm

#### Displacement controls:

**ES** - Electric motor displacement control

**HG** - Handwheel displacement control (Special feature)

**FE** - Screw adjustment control (Special feature)

**DF** - Pressure compensator controlled

**DQ** - Mooring control

**LR** - Power control with pressure limiter

**SP, SM** - Displacement proportional to electric signal

**DP** - Displacement proportional to pressure signal

#### Typical Section of Open Loop ATUS-PVX Pump

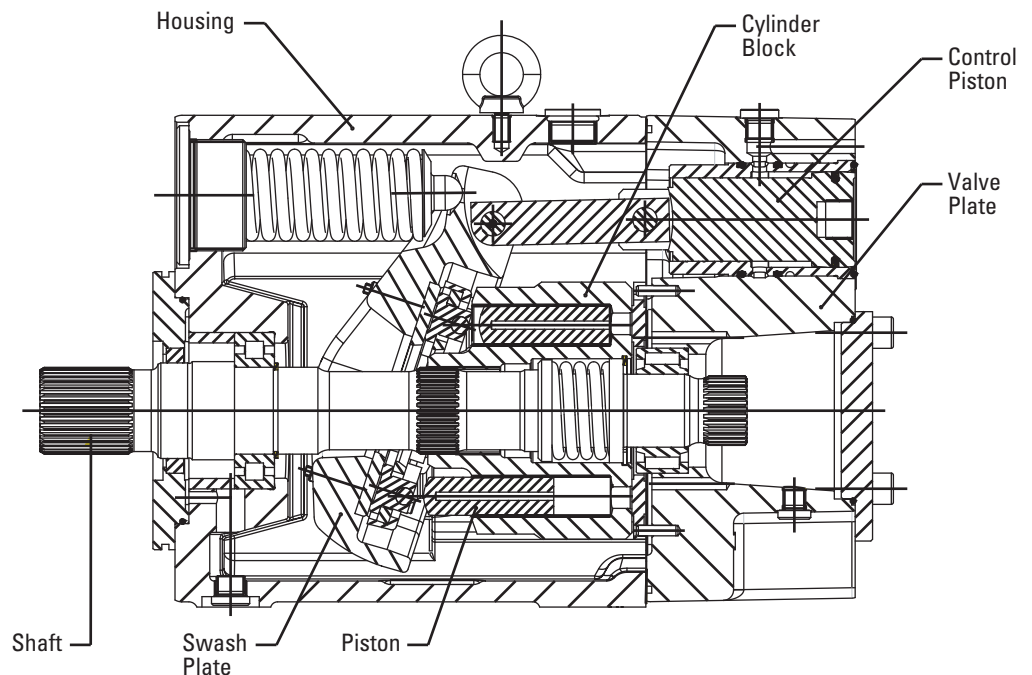

Dimensional information listed in this catalog is subject to change without notice.

## Model Code

Fixed & Variable Displacement Pumps

"X" Series

### Form Page

The following 48-digit coding system has been developed to identify all of the configuration options for the "X" series (Open Loop) fixed and variable displacement pumps. Use this model code to specify a unit with the desired features. All 48-digits must be present when ordering. You may want to photocopy the matrix below to ensure that each number is entered in the correct box. If adjustments other than the standard setting (character 40 ... 43) or special features (character 44 ... 48) are needed, please provide the information when ordering.

Some characters are already filled out on the following pages. For such characters there is no option available.

Explanation for each character can be found as follows:

	CHARACTER	PAGE
Basic Pump Model Code	1...23	6
Control Options	24...39	7 - 15
Customer Adjustment Specification	40...43	7 - 15
Special Features	44...46	16
Design Number	47...48	16

1	2	3	4	5	6	7	8	9	10	11	12	13	14	15	16	17	18	19	20	21	22	23		
P	X		-					M							1				S	V		A		
24	25	26	27	28	29	30	31	32	33	34	35	36	37	38	39	40	41	42	43	44	45	46	47	48
																							1	0

**SPECIFY NON STANDARD ADJUSTMENT BELOW**

---



---



---



---



---



---



---



---



---



---



---



---

**SPECIFY SPECIAL FEATURE BELOW**

---



---



---



---



---



---



---



---



---



---



---



# Model Code

Open Loop Pumps

"X" Series - Basic Pump

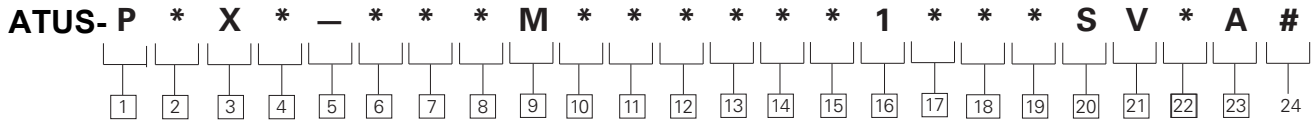

**1 Pump**  
P – Open Loop Pumps

**2 Displacement**  
F – Fixed  
V – Variable

**3 Pump Series**  
X – "X" Series  
(was 20 design)

**4 Configuration**  
S – Single Unit  
R – Rear Unit

**5 Separator**

**6 7 8 Displacement cm<sup>3</sup>/r**  
066 – 66 cm<sup>3</sup>/r [4.0 in<sup>3</sup>/rev]  
090 – 90 cm<sup>3</sup>/r [5.5 in<sup>3</sup>/rev]  
130 – 130 cm<sup>3</sup>/r [7.9 in<sup>3</sup>/rev]  
180 – 180 cm<sup>3</sup>/r [11.0 in<sup>3</sup>/rev]  
250 – 250 cm<sup>3</sup>/r [15.3 in<sup>3</sup>/rev]  
??? – Non-Standard Displacement (PFX Only)

**9 Basic Standard**  
M – Metric

**10 11 Mounting Flange**  
02 – ISO 3019/2-125A2HW  
04 – ISO 3019/2-160A2HW  
06 – ISO 3019/2-200A2HW  
\* See Chart Below

**12 Rotation Direction**  
R – Right Hand [CW]  
L – Left Hand [CCW]  
\*\* See Chart Below

**13 Adjustment Stops**  
0 – No Stop  
4 – Mechanical Adjustment Stop Side A (PVX only)  
5 – Mechanical Adjustment Stop Side B (PVX only)  
6 – Mechanical Adjustment Stops Side A and B (PVX only)

**NOTE:**  
4 is used as max. Adjustment on Side A.  
5 is used as min. Adjustment stop side A.  
6 is the combination of 4 and 5 together

**14 15 Thru-Drive Options**  
00 – None  
0A – SAE A  
0B – SAE B  
0C – SAE C  
0P – Pilot pump (8cm<sup>3</sup>/r) (PVX only)  
\*\*\* See Chart Below

**16 Main Ports**  
1 – SAE ports - metric bolts

**17 Main Port Orientation**  
A – Axial (in-line rear)  
R – Radial (side ports)

**18 19 Main Drive Shaft End**  
01 – ISO straight key  
02 – ISO spline

**20 Drive Shaft Seal Configuration**  
S – Single shaft seal

**21 Seal Material**  
V – Viton\*\*

**22 Yoke Position Indicator**  
0 – No position indicator  
V – Visual position indicator  
P – Position sensor  
M – Sensor w/visual indicator

**23 Surface Finish**  
A – Blue painted

**24 Add Control Model Code**  
Code (characters 24...43) on the following pages

*MOUNTING FLANGE OPTIONS AVAILABLE	066	090	130	180	250
ISO 3019/2-125A2HW	•	•			
ISO 3019/2-160A2HW			•	•	
ISO 3019/2-200A2HW					•

**ROTATION DIRECTION	066	090	130	180	250
Right Hand	•	•	•	•	•
Left Hand	•	•	•	•	

***THRU-DRIVE OPTIONS	066	090	130	180	250
SAE A	•	•	•	•	•
SAE B			•	•	•

## Model Code

Open Loop Pumps

"X" Series - No Control

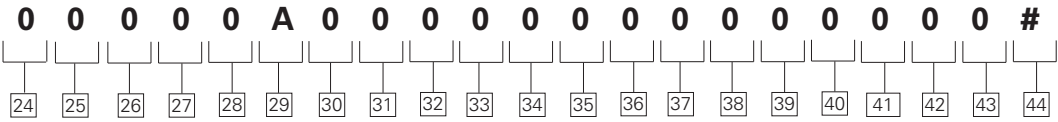

**24 25 Control Type**  
**00** – No Control  
 (For PFX only)

**26 Displacement Adjustment Options**  
**0** – Not Applicable

**27 28 Electronic Controls**  
**00** – Not Required

**29 Yoke Displacement Zone**  
**A** – Single Side of Center "A"

**30 Extra Functions**  
**0** – Not Required

**31 Pressure Control Options**  
**0** – Not Applicable

**32 33 34 Power Control**  
**000** – Not Applicable

**35 Pilot Oil Filter**  
**0** – Not Applicable

**36 Venting Valve**  
**0** – Not Applicable

**37 No Position Monitoring**  
**0** – No Position Monitoring

**38 Electric Motor Type**  
**0** – No Electric Motor

**39 Control Voltage**  
**0** – Not Applicable

**40 41 42 43 Customer Adjustment Specifications**  
**0000** – None

**44 Special Features**  
 Add special feature description (characters 44...46) on page 16 if required.



# Model Code

Open Loop Pumps

"X" Series - DF Control

**D F 0 0 0 A \* \* 0 0 0 0 \* 0 0 \* \* \* \* \* #**

24 25 26 27 28 29 30 31 32 33 34 35 36 37 38 39 40 41 42 43 44

**24 25 Control Type**  
**DF** – Pressure Compensator

**26 Displacement Adjustment Options**  
**0** – Not Applicable

**27 28 Electronic Controls**  
**00** – Not Required

**29 Yoke Displacement Zone**  
**A** – Single Side of Center "A"

**30 Extra Functions**  
**0** – Not Required  
**1** – Load Sensing Extra Function

**31 Pressure Control Options**  
**0** – Not Applicable  
**F** – Remote Port Only  
**K** – Electro Proportional Relief Valve- Incl. Electr. Card

**32 33 34 Power Control**  
**000** – Not Applicable

**35 Pilot Oil Filter**  
**0** – Not Applicable

**36 Venting Valve**  
**0** – Not Applicable  
**1** – With Solenoid Valve

**37 Position Monitoring**  
**0** – No Position Monitoring

**38 Electric Motor Type**  
**0** – No Electric Motor

**39 Control Voltage of Venting Valve**  
**0** – Not Applicable  
**B** – 110 AC 50 HZ/  
 120 AC 60 HZ  
**D** – 220 AC 50 HZ/  
 240 AC 60 HZ  
**G** – 12 VDC  
**J** – 24 VDC

**40 41 42 43 Customer Adjustment Specification**  
**0000** – None  
**????** – Yes (final number will be assigned by ATUS. Specify on table below)

**44 Special Features**  
 Add special feature description (characters 44...46) on page 16 if required.

**\*CUSTOMER ADJUSTMENT SPECIFICATIONS**

	Unit	Standard Adjustment	Customer Specified Adjustment	Remarks
All Revolution Adjustments below set at ..	rpm	1500	-	
Mech. Stop Side A (used as max Adjustment Stop Side A)	L/min	Q <sub>max</sub>		
Mech. Stop Side B (used as min Adjustment Stop Side B)	L/min	Q <sub>min</sub>		
Pressure Control Main Stage	bar	20	-	
Pressure Control Pilot Valve	bar	19		
Load Sense p	bar	15		<15 bar not possible



## Model Code

Open Loop Pumps

"X" Series - DQ Control

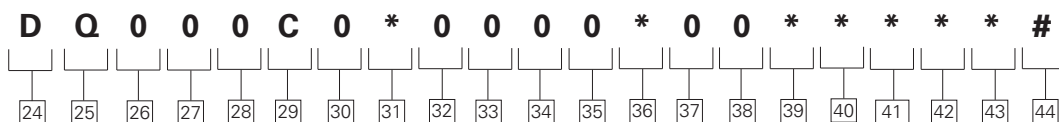

**24 25 Control Type**  
**DQ** – Mooring Control

**26 Displacement Adjustment Options**  
**0** – Not Applicable

**27 28 Electronic Controls**  
**00** – Not Required

**29 Yoke Displacement Zone**  
**C** – Over Center

**30 Extra Functions**  
**0** – Not Required

**31 Pressure Control Options**  
**0** – Not Applicable  
**F** – Remote Port Only  
**K** – Electro Proportional Relief Valve– Incl. Electr. Card

**32 33 34 Power Control**  
**000** – Not Applicable

**35 Pilot Oil Filter**  
**0** – Not Applicable

**36 Venting Valve**  
**0** – Not Applicable  
**1** – With Solenoid Valve

**37 Position Monitoring**  
**0** – No Position Monitoring

**38 Electric Motor Type**  
**0** – No Electric Motor

**39 Control Voltage of Venting Valve**  
**0** – Not Applicable  
**B** – 110 AC 50 HZ/  
 120 AC 60 HZ  
**D** – 220 AC 50 HZ/  
 240 AC 60 HZ  
**G** – 12 VDC  
**J** – 24 VDC

**40 41 42 43 Customer Adjustment Specification**  
**0000** – None  
**????** – Yes (final number will be assigned by ATUS. Specify on table below)

**44 Special Features**  
 Add special feature description (characters 44...46) on page 16 if required.

**MOORING CONTROL AVAILABLE ON THE FOLLOWING FRAMES**

	Available	Not Available
066	*	
090		*
130	*	
180	*	
250		*

**\*CUSTOMER ADJUSTMENT SPECIFICATIONS**

	Unit	Standard Adjustment	Customer Specified Adjustment	Remarks
All Revolution Adjustments below set at ..	rpm	1500	-	
Mech. Stop Side A (used as max Adjustment Stop Side A)	L/min	Q <sub>max</sub>		
Mech. Stop Side B (used as min Adjustment Stop Side B)	L/min	Q <sub>min</sub>		
Pressure Control Main Stage	bar	20	-	
Pressure Control Pilot Valve	bar	90		



# Model Code

Open Loop Pumps

"X" Series - LR Control

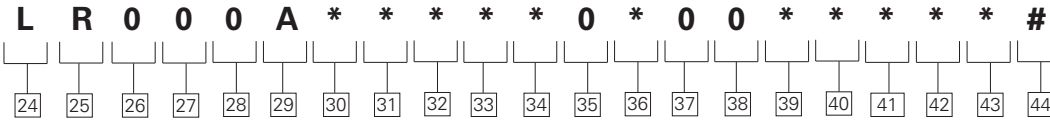

**[24][25] Control Type**  
**LR** – Power Control

**[26] Displacement Adjustment Options**  
**0** – Not Applicable

**[27][28] Electronic Controls**  
**00** – Not Required

**[29] Yoke Displacement Zone**  
**A** – Single Side of Center "A"

**[30] Extra Functions**  
**2** – Pressure Limiter Extra Function  
**3** – Load Sense & Pressure Limiter Extra Function

**[31] Pressure Control Options**  
**0** – Not Applicable  
**F** – Remote Port Only  
**K** – Electro Proportional Relief Valve– Incl. Electr. Card

**[32][33][34] Power Control**  
**???** – KW at 1500 rpm

**[35] Pilot Oil Filter**  
**0** – Not Applicable

**[36] Venting Valve**  
**0** – Not Applicable  
**1** – With Solenoid Valve

**[37] Position Monitoring**  
**0** – No Position Monitoring

**[38] Electric Motor Type**  
**0** – No Electric Motor

**[39] Control Voltage of Venting Valve**  
**0** – Not Applicable  
**B** – 110 AC 50 HZ/  
 120 AC 60 HZ  
**D** – 220 AC 50 HZ/  
 240 AC 60 HZ  
**G** – 12 VDC  
**H** – 24 VDC

**[41][42][43] Customer Adjustment Specification**  
**0000** – None  
**????** – Yes (final number will be assigned by ATUS. Specify on table below)

**[44] Special Features**  
 Add special feature description (characters 44...46) on page 16 if required.

**\*CUSTOMER ADJUSTMENT SPECIFICATIONS**

	Unit	Standard Adjustment	Customer Specified Adjustment	Remarks
All Revolution Adjustments below set at ..	rpm	1500		
Mech. Stop Side A (used as max Adjustment Stop Side A)	L/min	Q <sub>max</sub>		
Mech. Stop Side B (used as min Adjustment Stop Side B)	L/min	Q <sub>min</sub>		
Pressure Control Main Stage	bar	20		
Pressure Control Pilot Valve	bar	90		
Load Sense p	bar	15		<15 bar not possible

## Model Code

Open Loop Pumps

"X" Series - ES Control

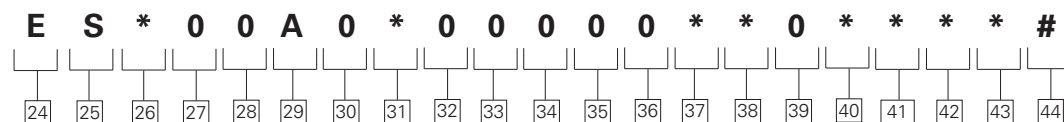

**24 25 Control Type**  
**ES** – Electric Motor Displacement

**26 Displacement Adjustment Options**  
**M** – Electric Motor - Fast Response\*  
**N** – Electric Motor - Medium Response\*  
**P** – Electric Motor - Slow Response\*

**27 28 Electronic Controls**  
**00** – Not Required

**29 Yoke Displacement Zone**  
**A** – Single Side of Center "A"

**30 Extra Functions**  
**0** – Not Required

**31 Pressure Control Options**  
**0** – Not Applicable

**32 33 34 Power Control**  
**000** – Not Applicable

**35 Pilot Oil Filter**  
**0** – Not Applicable

**36 Venting Valve**  
**0** – Not Applicable

**37 Position Monitoring**  
**A** – 4 Limit Switches  
**B** – 8 Limit Switches  
**P** – 4 Limit Switches w/Sensor  
**T** – 8 Limit Switches w/Sensor

**38 Electric Motor Type**  
**2** – Motor With Brake (IP-54)  
**3** – Motor Without Brake (Explosion Proof)

**39 Control Voltage of Venting Valve**  
**0** – Not Applicable

**40 41 42 43 Customer Adjustment Specification**

**0000** – None  
**????** – Yes (final number will be assigned by ATUS. Specify on table below)

**44 Special Features**

Add special feature description (characters 44...46) on page 16 if required.

Response Time (sec) for Zero to max. Displacement

SIZE	066/090		130/180		250	
	50 Hz	60 Hz	50 Hz	60 Hz	50 Hz	60 Hz
Frequency Fast	7	6	18	15	15	13
Medium	24	20	35	29	30	25
Slow	38	32	54	45	48	40

**\*\*CUSTOMER ADJUSTMENT SPECIFICATIONS**

	Unit	Standard Adjustment	Customer Specified Adjustment	Remarks
All Revolution Adjustments below set at ..	rpm	1500		
Mech. Stop Side A (used as max Adjustment Stop Side A)	L/min	Q <sub>max</sub>		
Mech. Stop Side B (used as min Adjustment Stop Side B)	L/min	Q <sub>min</sub>		
Displacement Adjusted to...	cm <sup>3</sup> /rev.	~50% Q <sub>max</sub>		
Position Monitoring Switch	L/min	0		
	L/min	95% of Q <sub>max</sub>		<95% not possible
	L/min			
	L/min			
	L/min			
	L/min			
	L/min			
	L/min			



# Model Code

Open Loop Pumps

"X" Series - HG Control

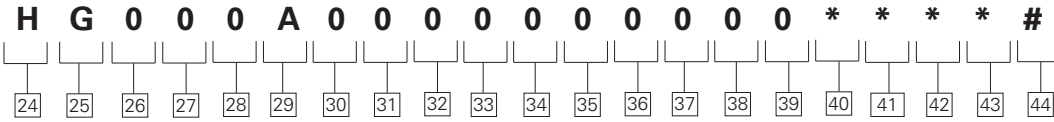

**24 25 Control Type**

**HG** – Handwheel Displacement Control

**26 Displacement Adjustment Options**

**0** – Not Applicable

**27 28 Electronic Controls**

**00** – Not Required

**29 Yoke Displacement Zone**

**A** – Single Side of Center "A"

**30 Extra Functions**

**0** – Not Required

**31 Pressure Control Options**

**0** – Not Applicable

**32 33 34 Power Control**

**000** – Not Applicable

**35 Pilot Oil Filter**

**0** – Not Applicable

**36 Venting Valve**

**0** – Not Applicable

**37 Position Monitoring**

**0** – No Position Monitoring

**38 Electric Motor Type**

**0** – No Electric Motor

**39 Control Voltage of Venting Valve**

**0** – Not Applicable

**40 41 42 43 Customer Adjustment Specification**

**0000** – None

**????** – Yes (final number will be assigned by ATUS. Specify on table below)

**44 Special Features**

Add special feature description (characters 44...46) on page 16 if required.

**\*CUSTOMER ADJUSTMENT SPECIFICATIONS**

	Unit	Standard Adjustment	Customer Specified Adjustment	Remarks
All Revolution Adjustments below set at ..	rpm	1500		
Displacement Adjusted to...	L/min	Q <sub>max</sub>		

## Model Code

Open Loop Pumps

"X" Series - FE Control

**F E 0 0 0 A 0 0 0 0 0 0 0 0 0 0 \* \* \* \* #**

24 25 26 27 28 29 30 31 32 33 34 35 36 37 38 39 40 41 42 43 44

**24 25 Control Type**  
**FE** – Screw Adjustment Displacement Control

---

**26 Displacement Adjustment Options**  
**0** – Not Applicable

---

**27 28 Electronic Controls**  
**00** – Not Required

---

**29 Yoke Displacement Zone**  
**A** – Single Side of Center "A"

**30 Extra Functions**  
**0** – Load Sensing Extra Function

---

**31 Pressure Control Options**  
**0** – Not Applicable

---

**32 33 34 Power Control**  
**000** – Not Applicable

---

**35 Pilot Oil Filter**  
**0** – Not Applicable

**36 Venting Valve**  
**0** – Not Applicable

---

**37 Position Monitoring**  
**0** – No Position Monitoring

---

**38 Electric Motor Type**  
**0** – No Electric Motor

---

**39 Control Voltage of Venting Valve**  
**0** – Not Applicable

**41 42 43 Customer Adjustment Specification**  
**0000** – None  
**????** – Yes (final number will be assigned by ATUS. Specify on table below)

---

**44 Special Features**  
 Add special feature description (characters 44...46) on page 16 if required.

**\*CUSTOMER ADJUSTMENT SPECIFICATIONS**

	Unit	Standard Adjustment	Customer Specified Adjustment	Remarks
All Revolution Adjustments below set at ..	rpm	1500		
Displacement Adjusted to...	L/min	Q <sub>max</sub>		

# Model Code

Open Loop Pumps

"X" Series - DP Control

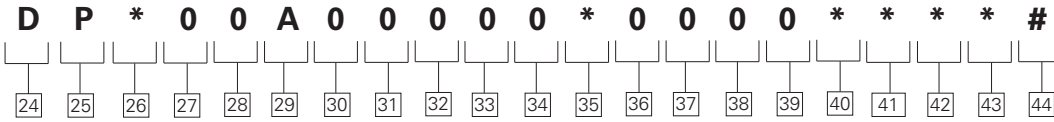

- 24 25 Control Type**  
**DP** – Pressure Signal Adjustment Displacement Control
- 
- 26 Displacement Adjustment Options**  
**G** – Mounting Interface CETOP 3 Only  
**H** – Remote Port G 1/4  
**J** – Proportional Relief Inc. Electronics
- 
- 27 28 Electronic Controls**  
**00** – Not Required

- 29 Yoke Displacement Zone**  
**A** – Single Side of Center "A"
- 
- 30 Extra Functions**  
**0** – Not Required
- 
- 31 Pressure Control Options**  
**0** – Not Applicable
- 
- 32 33 34 Power Control**  
**000** – Not Applicable

- 35 Pilot Oil Filter**  
**0** – Not Applicable  
**V** – Filter with Visual Indicator  
**E** – Filter with Electrical Indicator
- 
- 36 Venting Valve**  
**0** – Not Applicable
- 
- 37 Position Monitoring**  
**0** – No Position Monitoring
- 
- 38 Electric Motor Type**  
**0** – No Electric Motor

- 39 Control Voltage of Venting Valve**  
**0** – Not Applicable
- 
- 40 41 42 43 Customer Adjustment Specification**  
**0000** – None  
**????** – Yes (final number will be assigned by ATUS. Specify on table below)
- 
- 44 Special Features**  
 Add special feature description (characters 44...46) on page 16 if required.

**\*CUSTOMER ADJUSTMENT SPECIFICATIONS**

	Unit	Standard Adjustment	Customer Specified Adjustment	Remarks
All Revolution Adjustments below set at ..	rpm	1500	-	
Pilot Pressure	bar	60		
Mech. Stop Side A (used as max Adjustment Stop Side A)	L/min	Q <sub>max</sub>		
Mech. Stop Side B (used as min Adjustment Stop Side B)	L/min	Q <sub>min</sub>		

## Model Code

Open Loop Pumps

"X" Series - SP Control

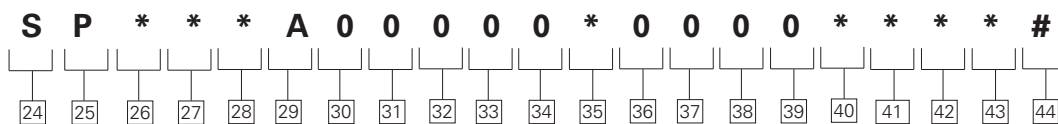

- 24 25 Control Type**  
**SP** – Proportional Valve Adjustment Displacement Control

---

- 26 Displacement Adjustment Options**  
**C** – With CETOP 3 Prop Valve KDG4V 3  
**F** – With CETOP 5 Prop Valve

---

- 27 28 Electronic Controls**  
**03** – ER 9.3 - 10 (CETOP 3)  
**04** – ER 9.4 - 10 (CETOP 5)

- 29 Yoke Displacement Zone**  
**A** – Single Side of Center "A"

---

- 30 Extra Functions**  
**0** – Not Required

---

- 31 Pressure Control Options**  
**0** – Not Applicable

---

- 32 33 34 Power Control**  
**000** – Not Applicable

---

- 35 Pilot Oil Filter**  
**V** – Filter with Visual Indicator  
**E** – Filter with Electrical Indicator

- 36 Venting Valve**  
**0** – Not Applicable

---

- 37 Position Monitoring**  
**0** – No Position Monitoring

---

- 38 Electric Motor Type**  
**0** – No Electric Motor

---

- 39 Control Voltage of Venting Valve**  
**0** – Not Applicable

- 40 41 42 43 Customer Adjustment Specification**  
**0000** – None  
**????** – Yes (final number will be assigned by ATUS. Specify on table below)

---

- 44 Special Features**  
 Add special feature description (characters 44...46) on page 16 if required.

**\*CUSTOMER ADJUSTMENT SPECIFICATIONS**

	Unit	Standard Adjustment	Customer Specified Adjustment	Remarks
All Revolution Adjustments below set at ..	rpm	1500	-	
Pilot Pressure	bar	60	-	
Mech. Stop Side A (used as max Adjustment Stop Side A)	L/min	Q <sub>max</sub>		
Mech. Stop Side B (used as min Adjustment Stop Side B)	L/min	Q <sub>min</sub>		
Max. Stop by Control Side A	L/min	95% Q <sub>max</sub>	El Card Adjustment done by customer	Refer to El card Manual
Min. Stop by Control Side A	L/min	0+/-2.5%	El Card Adjustment done by customer	Refer to El card Manual
Ramp Time 0 → A For 100% Stroke	sec	0	El Card Adjustment done by customer	Refer to El card Manual
Ramp Time A → 0 For 100% Stroke	sec	0	El Card Adjustment done by customer	Refer to El card Manual
Preset Input Signals S1....S4	L/min	-	El Card Adjustment done by customer	Refer to El card Manual



# Model Code

Open Loop Pumps

"X" Series - Special Features

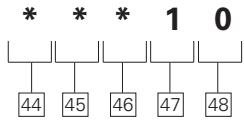

**44 45 46 Special Features**

**000** – None

**\*\*\*** – Defined by ATUS.

---

**47 48 Design Number**

**10** – Design Number



## Model Code

### Combination Units

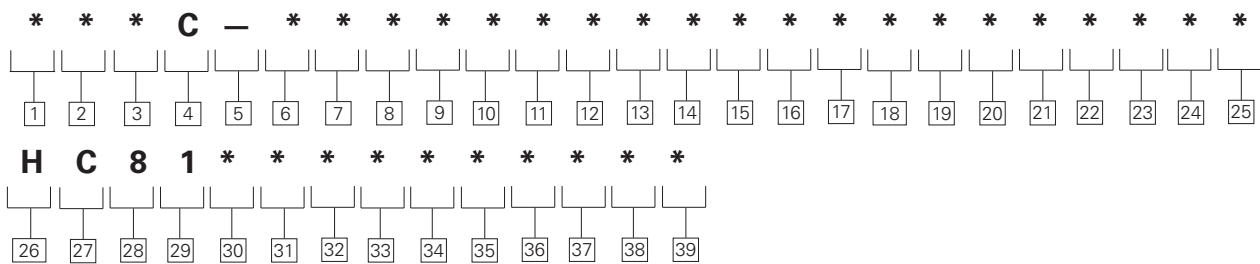

**1 Combination Unit**

- P** – Pump
- T** – Transmission Pump
- M** – Motor

**2 Displacement**

- F** – Filled
- V** – Variable

**3 Pump Series**

- W** – “W” Series  
(was 30 design)
- X** – “X” Series  
(was 20 design)

**4 Combination Unit**

**C**

**5 Separator**

**6 7 8 First**

- Displacement cm<sup>3</sup>/r**
- 066** – 66 cm<sup>3</sup>/r [4.0 in<sup>3</sup>/rev]
  - 090** – 90 cm<sup>3</sup>/r [5.5 in<sup>3</sup>/rev]
  - 130** – 130 cm<sup>3</sup>/r [7.9 in<sup>3</sup>/rev]
  - 180** – 180 cm<sup>3</sup>/r [11.0 in<sup>3</sup>/rev]
  - 250** – 250 cm<sup>3</sup>/r [15.3 in<sup>3</sup>/rev]
  - 360** – 360 cm<sup>3</sup>/r [22.0 in<sup>3</sup>/rev]
  - 500** – 500 cm<sup>3</sup>/r [30.5 in<sup>3</sup>/rev]
  - 750** – 750 cm<sup>3</sup>/r [45.8 in<sup>3</sup>/rev]

**9 10 First Control Type**

- 00** – No Control (for Fixed Displacement Only)
- DF** – Pressure Compensator
- LR** – Power Control
- ES** – Electric Motor Control
- HG** – Handwheel  
Displacement Control
- FE** – Screw Adjustment  
Displacement Control
- SM** – Servo Adjustment  
Displacement Control -  
Mech Feedback
- DP** – Pressure Signal  
Displacement Control
- SP** – Proportional Valve  
Displacement Control

**11 12 13 Second**

- Displacement cm<sup>3</sup>/r**
- 066** – 66 cm<sup>3</sup>/r [4.0 in<sup>3</sup>/rev]
  - 090** – 90 cm<sup>3</sup>/r [5.5 in<sup>3</sup>/rev]
  - 130** – 130 cm<sup>3</sup>/r [7.9 in<sup>3</sup>/rev]
  - 180** – 180 cm<sup>3</sup>/r [11.0 in<sup>3</sup>/rev]
  - 250** – 250 cm<sup>3</sup>/r [15.3 in<sup>3</sup>/rev]
  - 360** – 360 cm<sup>3</sup>/r [22.0 in<sup>3</sup>/rev]
  - 500** – 500 cm<sup>3</sup>/r [30.5 in<sup>3</sup>/rev]
  - 750** – 750 cm<sup>3</sup>/r [45.8 in<sup>3</sup>/rev]

**14 15 Second Control Type**

- 00** – No Control (for Fixed Displacement Only)
- DF** – Pressure Compensator
- LR** – Power Control
- ES** – Electric Motor Control
- HG** – Handwheel  
Displacement Control
- FE** – Screw Adjustment  
Displacement Control
- SM** – Servo Adjustment  
Displacement Control -  
Mech Feedback
- DP** – Pressure Signal  
Displacement Control
- SP** – Proportional Valve  
Displacement Control

**16 17 18 Third**

- Displacement cm<sup>3</sup>/r**
- 000** – Not Required
  - 066** – 66 cm<sup>3</sup>/r [4.0 in<sup>3</sup>/rev]
  - 090** – 90 cm<sup>3</sup>/r [5.5 in<sup>3</sup>/rev]
  - 130** – 130 cm<sup>3</sup>/r [7.9 in<sup>3</sup>/rev]
  - 180** – 180 cm<sup>3</sup>/r [11.0 in<sup>3</sup>/rev]
  - 250** – 250 cm<sup>3</sup>/r [15.3 in<sup>3</sup>/rev]
  - 360** – 360 cm<sup>3</sup>/r [22.0 in<sup>3</sup>/rev]
  - 500** – 500 cm<sup>3</sup>/r [30.5 in<sup>3</sup>/rev]
  - 750** – 750 cm<sup>3</sup>/r [45.8 in<sup>3</sup>/rev]

**19 20 Third Control Type**

- 00** – No Control (for Fixed Displacement Only)
- DF** – Pressure Compensator
- LR** – Power Control
- ES** – Electric Motor Control
- HG** – Handwheel  
Displacement Control
- FE** – Screw Adjustment  
Displacement Control
- SM** – Servo Adjustment  
Displacement Control -  
Mech Feedback
- DP** – Pressure Signal  
Displacement Control
- SP** – Proportional Valve  
Displacement Control

**21 22 23 Fourth**

- Displacement cm<sup>3</sup>/r**
- 000** – Not Required
  - 066** – 66 cm<sup>3</sup>/r [4.0 in<sup>3</sup>/rev]
  - 090** – 90 cm<sup>3</sup>/r [5.5 in<sup>3</sup>/rev]
  - 130** – 130 cm<sup>3</sup>/r [7.9 in<sup>3</sup>/rev]
  - 180** – 180 cm<sup>3</sup>/r [11.0 in<sup>3</sup>/rev]
  - 250** – 250 cm<sup>3</sup>/r [15.3 in<sup>3</sup>/rev]
  - 360** – 360 cm<sup>3</sup>/r [22.0 in<sup>3</sup>/rev]
  - 500** – 500 cm<sup>3</sup>/r [30.5 in<sup>3</sup>/rev]
  - 750** – 750 cm<sup>3</sup>/r [45.8 in<sup>3</sup>/rev]

**24 25 Fourth Control Type**

- 00** – No Control (for Fixed Displacement Only)
- DF** – Pressure Compensator
- LR** – Power Control
- ES** – Electric Motor Control
- HG** – Handwheel  
Displacement Control
- FE** – Screw Adjustment  
Displacement Control
- SM** – Servo Adjustment  
Displacement Control -  
Mech Feedback
- DP** – Pressure Signal  
Displacement Control
- SP** – Proportional Valve  
Displacement Control

**26 27 28 29 Assembly Numbers**

**HC81** – Defined By ATUS

**30 31 32 33 34 35 36 37 38 39 Assembly Numbers**

Defined By ATUS

- For a combination of two or more units fill out this Combination Model Code.
- Start with the biggest size unit for the first displacement.
- For each unit included in this combination, a separate model code must be chosen. Use the form on page 4.
- Character 26 to 39 will be P/N of the combination. This number will be defined by ATUS and provided in the order acknowledgement.
- Charge and Pilot Pump through drive option must be specified on the rear unit of the combination (as a special feature).
- Front and middle units shall have the through drive option of the following unit in the combination.



## Model Code

Examples for  
Combination Units

### Example 1: Combination of two open loop pumps

Model Code Front Unit

ATUS-PVWF-500M08R0001R02SVMASPC03A000000000000000010

Model Code Rear Unit

ATUS-PVXR-250M07R0001R02SVMASPC03A000000000000000010

Model Code Combination Unit

ATUS-PVWC-500SP250SP0000000000HC81\*\*\*\*\*

### Example 2: Combination of one closed loop - and two open loop pumps (For other product model codes refer to the according catalog)

Mode Code Front Unit

ATUS-TVWF-500M08R0000H1R02SVMA20SPC03C00000000E000H000000010

Model Code Middle Unit

ATUS-PVWM-250M07R0001R02SV0ADF000A000000000000000010

Model Code Rear Unit

ATUS-PFXR-130M02R00P1A02SV0A00000A000000000000000010

Model Code Combination Unit

ATUS-TVWC-500SP250DF1300000000HC81\*\*\*\*\*

## Pump Specifications - US

MODEL			66	90	130	180	250
Design			Swashplate - Axial piston pump				
Type of mounting			Flange or foot-mounted. tandem is foot mounted only				
Pipe connection SAE Flange	B A	psi	1 1/2" = 3000 1" = 6000	2" = 3000 1" = 6000	2 1/2" = 3000 1" = 6000	2 1/2" = 3000 1 1/4" = 6000	3 1/2" = 500 1 1/4" = 6000
Direction of rotation			Clockwise when viewing shaft end of pump Counterclockwise available on request				
Speed range	n <sub>min</sub> n <sub>max</sub>	rpm	150 1800				
Installation position			Optional, see mounting information				
Ambient temperature range	min max	°F	-4 122				
Weight	m	lb	121	165	234	251	467
Mass of inertia	J	lb ft <sup>2</sup>	0.38	0.38	1.068	1.068	3.465

### HYDRAULIC CHARACTERISTICS

Nominal pressure (100% duty cycle)	p <sub>N</sub>	psi	5000					
Input pressure	p <sub>1min</sub>	psi	12.5 abs					
	p <sub>1max</sub>	psi	725					
Maximum pressure to DIN 24312	p <sub>2max</sub>	psi	6090					
Hydraulic fluid	Hydraulic oil to DIN 51524 part 2. Refer to section Application Data-Fluid Recommendations							
Hydraulic fluid temperature range	min max	°F	-13 (on startup) 194					
Viscosity range for continuous operation	min	cSt	10					
	max	cSt	75					
Maximum permissible start viscosity	max	cSt	1000					
Filtering	ISO 4406		18/15/13					
Maximum geometric displacement	n= 1500 rpm n= 1800 rpm	V <sub>g</sub>	in <sup>3</sup>	4.1	5.5	7.9	11.0	15.2
Maximum geometric pump flow	n= 1500 rpm n= 1800 rpm	Q <sub>g</sub>	USgpm	26 32	36 43	52 62	71 86	99 119
Case pressure	p <sub>v max</sub>	psi	max. 7.2psi over p <sub>1</sub> . p <sub>max</sub> = 58 abs.					

### DRIVE

Maximum driving torque - single unit (p <sub>2 max</sub> , η= 100%)	M <sub>1 Single</sub>	lb.ft.	325	444	640	887	1233
Maximum power consumption - single unit (p <sub>2 max</sub> , η= 100%; n= 1800 rpm)	P <sub>1 Single</sub>	hp	93	126	182	254	355
Maximum driving torque limited to splined shaft only - comb. unit	M <sub>1 Comb.</sub>	lb.ft.	2x325	2x444	2x640	2x887	2x1233

# Pump Specifications - Metric

MODEL			66	90	130	180	250
Design			Swashplate - Axial piston pump				
Type of mounting			Flange or foot-mounted. tandem is foot mounted only				
Pipe connection SAE/Flange	B A	psi	1 1/2" = 3000 1" = 6000	2" = 3000 1" = 6000	2 1/2" = 3000 1" = 6000	2 1/2" = 3000 1 1/4" = 6000	3 1/2" = 500 1 1/4" = 6000
Direction of rotation			Clockwise when viewing shaft end of pump Counterclockwise available on request				
Speed range	n <sub>min</sub> n <sub>max</sub>	min <sup>-1</sup>	150 1800				
Installation position			Optional, see mounting information				
Ambient temperature range	min max	°C	-20 50				
Weight	m	kg	55	75	106	114	212
Mass of inertia	J	kg m <sup>2</sup>	0.016	0.016	0.045	0.045	0.146

## HYDRAULIC CHARACTERISTICS

Nominal pressure (100% duty cycle)	p <sub>N</sub>	bar	350					
Input pressure	p <sub>1min</sub> p <sub>1max</sub>	bar	0.85 abs 50					
Maximum pressure to DIN 24312	p <sub>2max</sub>	bar	420					
Hydraulic fluid			Hydraulic oil to DIN 51524 part 2. Refer to section Application Data-Fluid Recommendations					
Hydraulic fluid temperature range	min max	°C	-25 (on start up) 90					
Viscosity range for continuous operation	min max	cSt cSt	10 75					
Maximum permissible start viscosity	max	cSt	1000					
Filtering	ISO 4406		18/15/13					
Maximum geometric displacement	n = 1500 min <sup>-1</sup> n = 1800 min <sup>-1</sup>	V <sub>g</sub>	cm <sup>3</sup>	66	90	130	180	250
Maximum geom. pump flow	n = 1500 min <sup>-1</sup> n = 1800 min <sup>-1</sup>	Q <sub>g</sub>	L/min	99 118	135 162	195 234	270 324	375 450
Case pressure	p <sub>v max</sub>	bar	max. 0,5 bar over p <sub>1</sub> . p <sub>max</sub> = 4 bar abs.					

## DRIVE

Maximum driving torque - single unit (p <sub>2 max</sub> , η = 100%)	M <sub>1 Single</sub>	Nm	440	600	868	1202	1671
Maximum power consumption - single unit (p <sub>2 max</sub> , η = 100%; n = 1800 min <sup>-1</sup> )	P <sub>1 Single</sub>	kW	69	94	136	189	265
Maximum driving torque limited to splined shaft only - comb. unit	M <sub>1 Comb.</sub>	Nm	2x440	2x600	2x868	2x1202	2x1671

Performance Curves -

066, 090, 130, 180, 250 Series

Outlet Flow and Theoretical Power Consumption

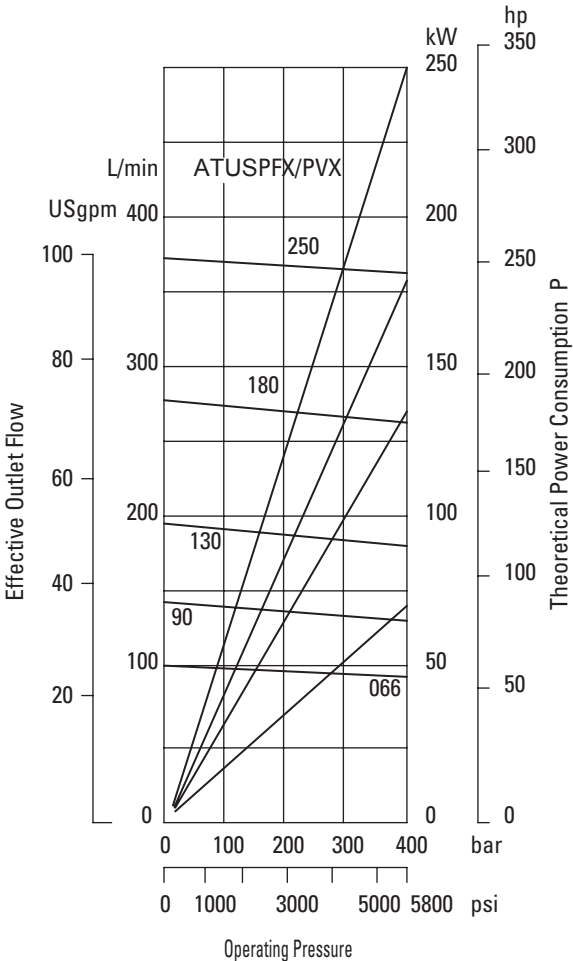

Typical at 1500 min<sup>-1</sup> with anti-wear oil at 40 cSt  
Single displacement pumps: ATUS-PFX, ATUSPVX

Volumetric and Overall Efficiencies

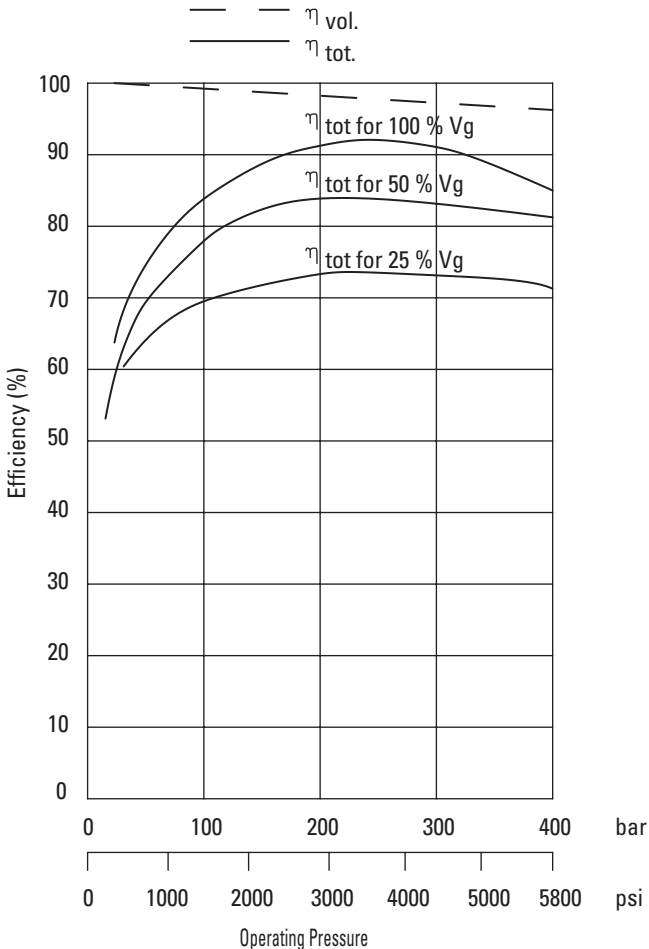

For Calculation:  $P_{eff} = P_{th} / \eta_{tot}$

# Performance Curves - Operating Data:

Theoretical Bearing Life Time  
066, 090, 130,  
180, 250 Series

At maximum displacement and various speeds.

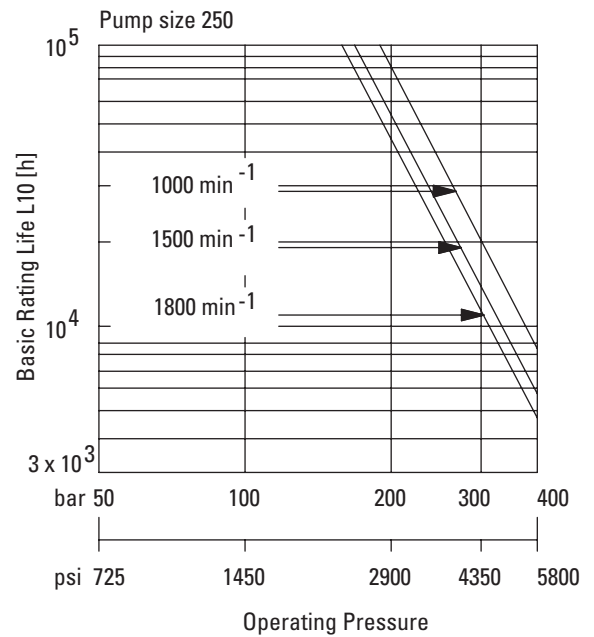
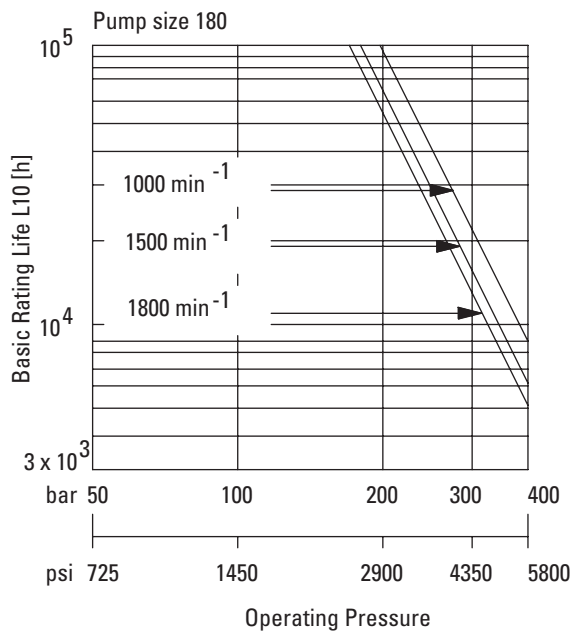
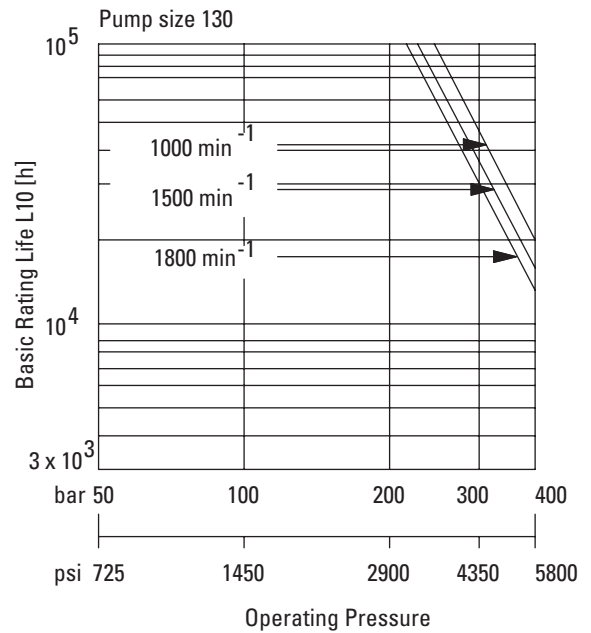
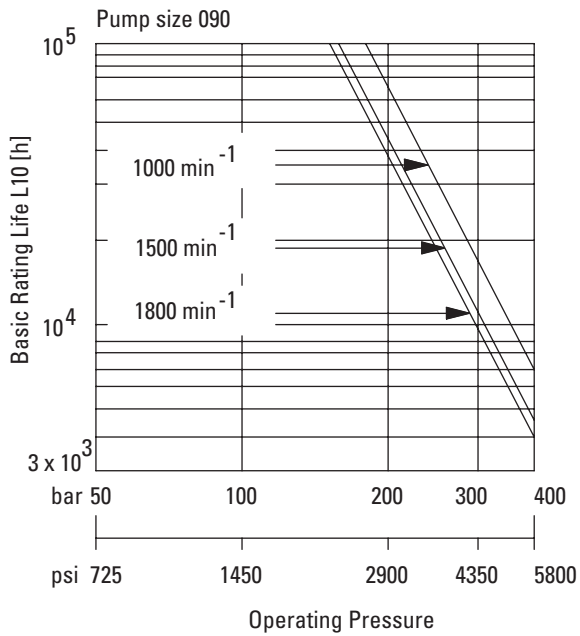
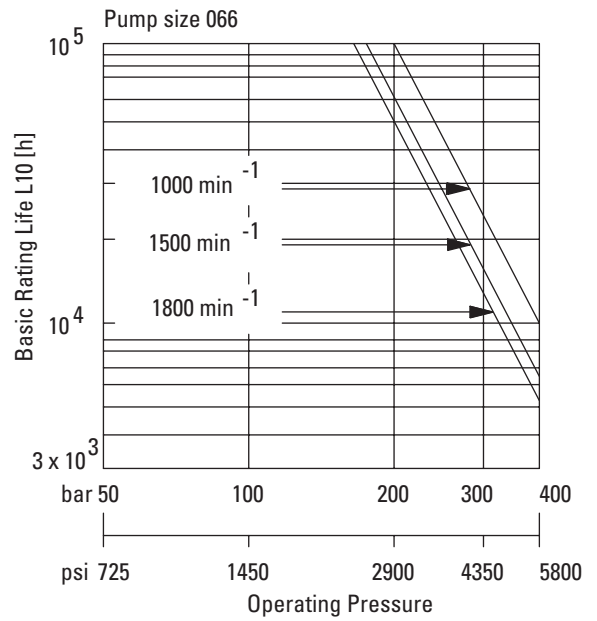

## Performance Curves - Operating Data:

Typical Drain Flow from an Open-Loop Pump Based on 1500 r/min and 35cSt

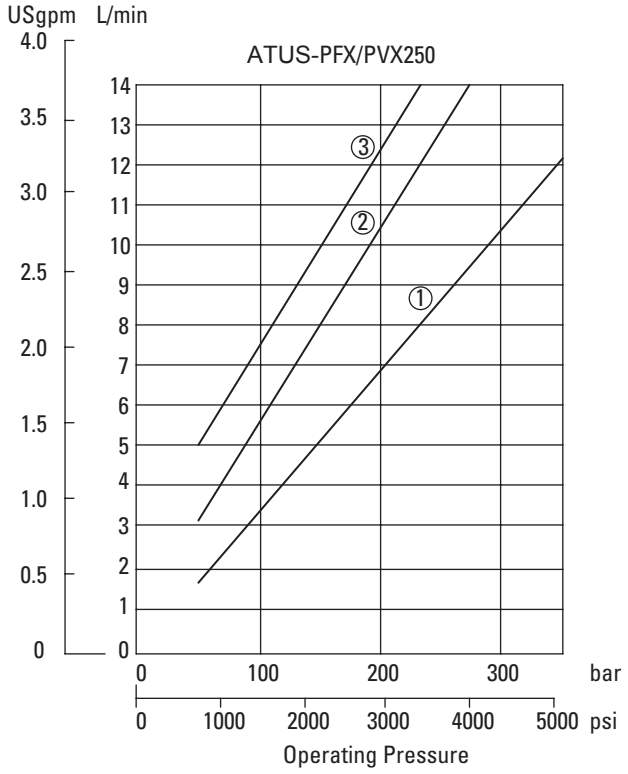
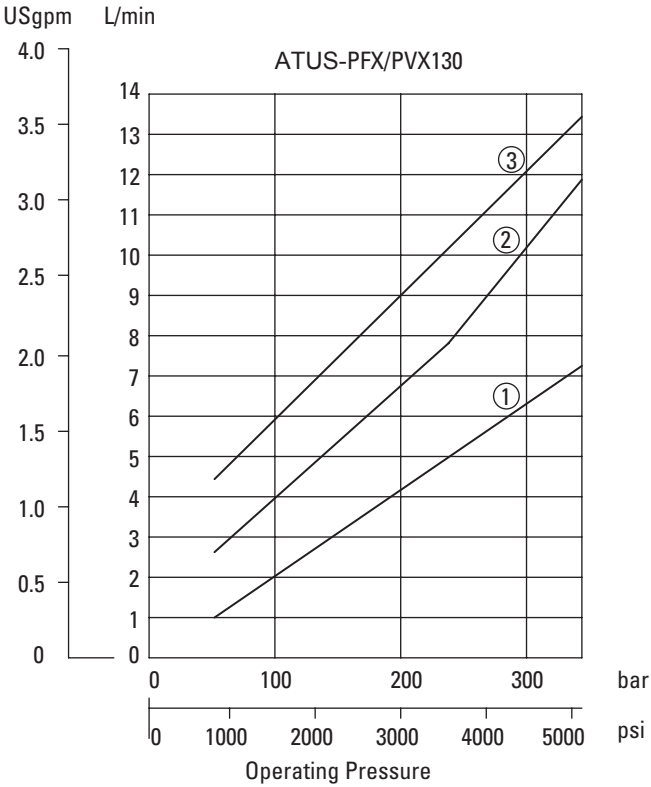
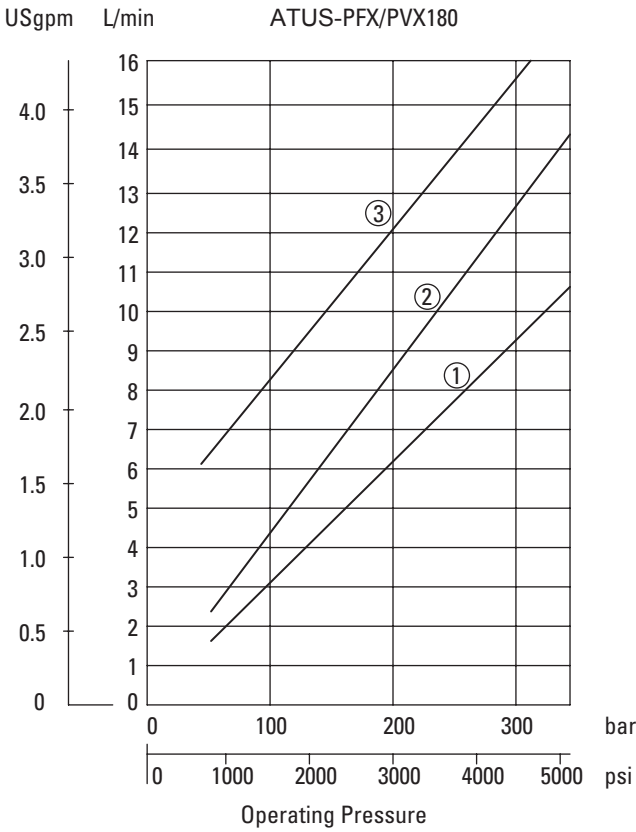
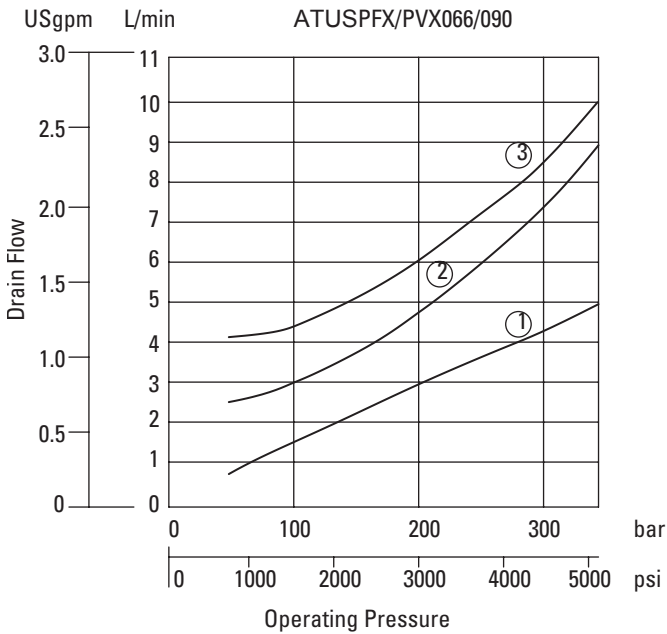

① ATUS-PFX and PVX models at maximum displacement (PVX models with type FE, HG or ES controls i.e. no control oil flow)

② ATUS-PVX in pressure cutoff mode (flow of pilot stage is discharged separately)

③ ATUS-PVX in pressure cutoff mode (flow of pilot stage is discharged in case)

# Controls - DF, LR Pressure Compensator/ Power Control

"X" Series - Open loop pump

Energy saving hydraulic drives are possible with pressure compensated and/or power controlled pumps, especially in combination with the load-sensing option.

**DF** The system pressure remains constant for the entire volume flow rate. System pressure can be set either manually, hydraulically or electronically. The standard Hydrokraft pressure compensator is pilot operated and very stable.

**LR** The  $p/Q$  characteristic curve is a hyperbola. For constant speed the drive torque, i.e. the power used, is held constant. The power hyperbola can be continuously adjusted between  $P_{min}$  and  $P_{max}$ .  $P_{min}$  is given by the minimum set value of control's main stage (app. 20 bar) and power loss of the pump. Both controllers can be combined with another or with additional options, for possible

variations see the model coding and circuit diagrams. The maximum flow of the pump can be limited mechanically to between 50% and 100% by screw. As an additional option the maximum (or minimum) flow can also be limited by a spacer inside the control cylinder (position number 13 in model coding, options 4, 5

or 6 in combination with customer adjustment specifications position 40-43 for the set values). This solution is also recommended for very rough operating conditions and the need of a very exact repeatability over a long time period. The setting must be defined before ordering and cannot be modified during operation.

### Typical controller action

(Closing/opening the directional control valve WV)  
 $Q \rightarrow Q_{max}$  or  $Q_{min} \rightarrow Q_{max}$   
 $C_H$  - 50mm ID x 2 meters

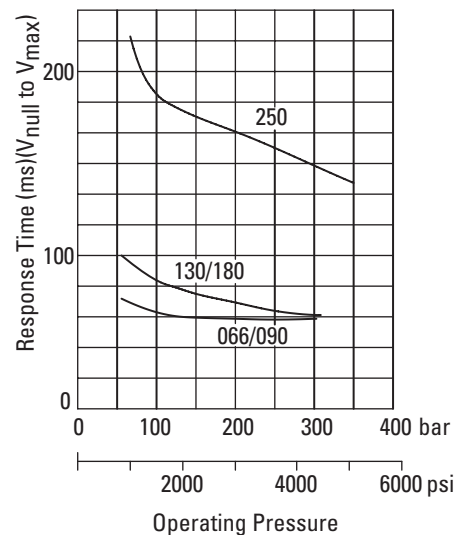
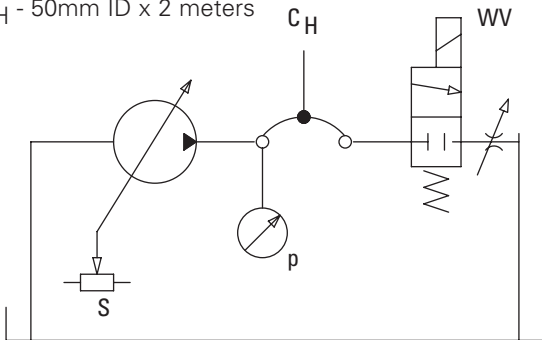

### Pressure compensator response times

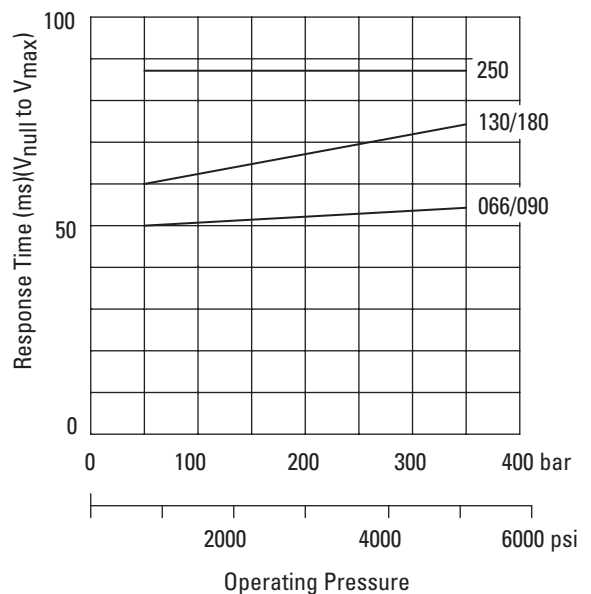
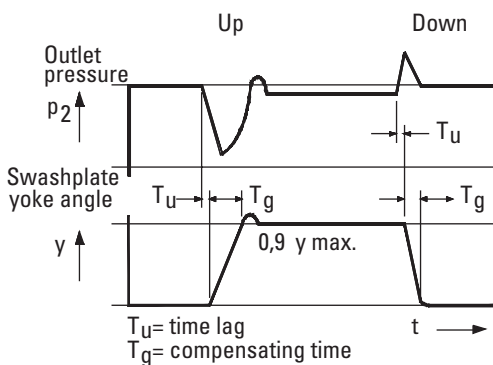



**Controls -  
DF, LR Pressure  
Compensator/  
Power Control**

"X" Series - Open loop pump

**DF Pressure compensator  
DF000A ...**

Control valve adjustable  
mechanically, electrically  
or remote port only

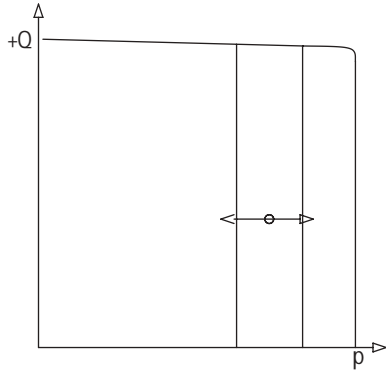
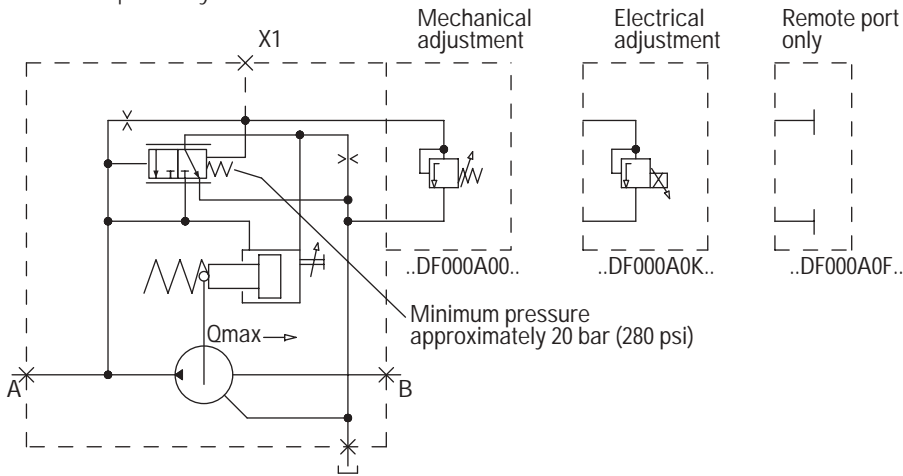

**LR Power control with  
overriding pressure  
limiter LR000A2 ...**

Pressure control pilot  
valve adjustable  
mechanically, electrically  
or remote port only

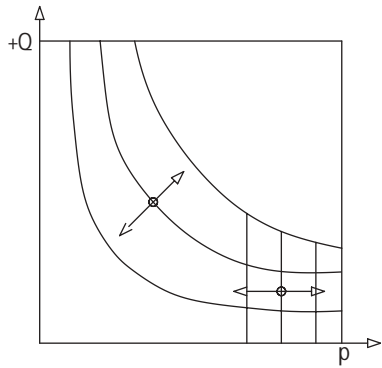
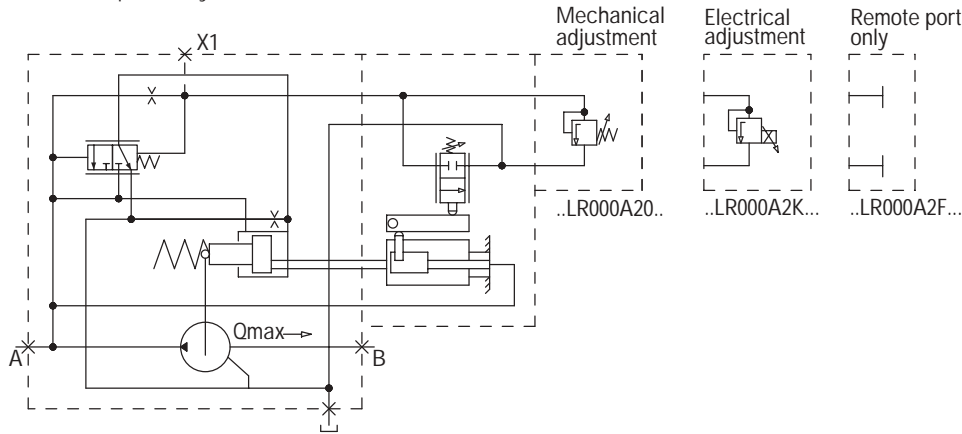

# Controls - DF, LR Pressure Compensator/ Power Control

"X" Series - Open loop pump

## DF Pressure compensator with load sensing DF000A1 ...

Control valve adjustable mechanically, electrically or remote port only

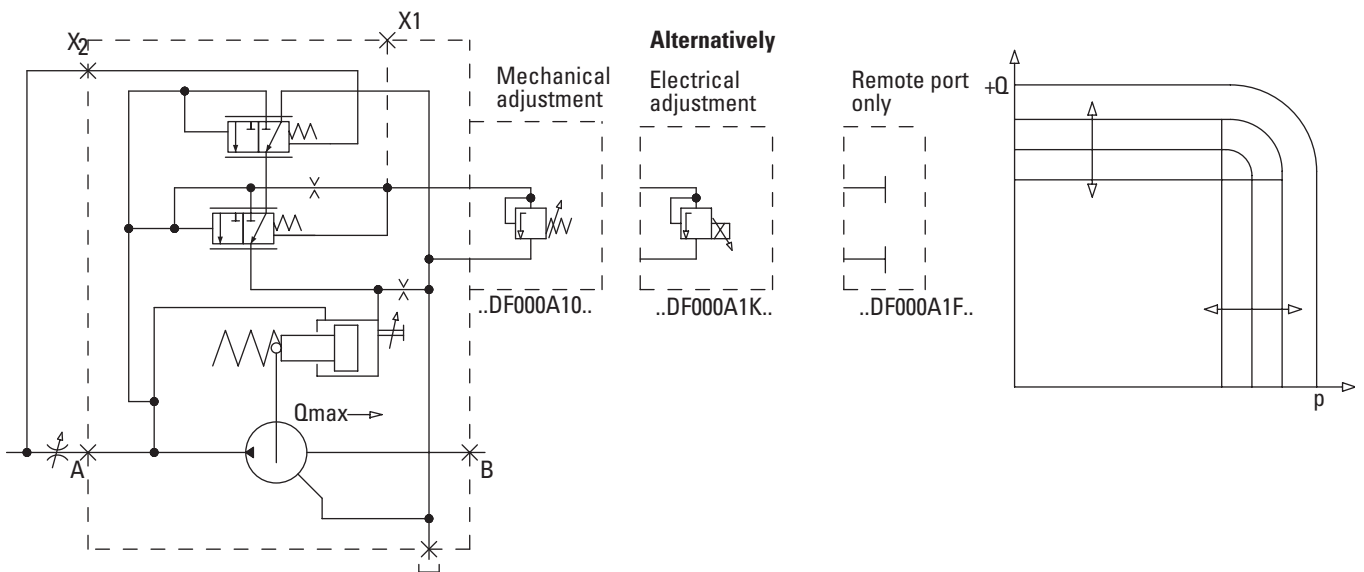

## LR Power control with load sensing and pressure limiter LR000A3 ...

Pressure control pilot valve adjustable mechanically, electrically or remote port only

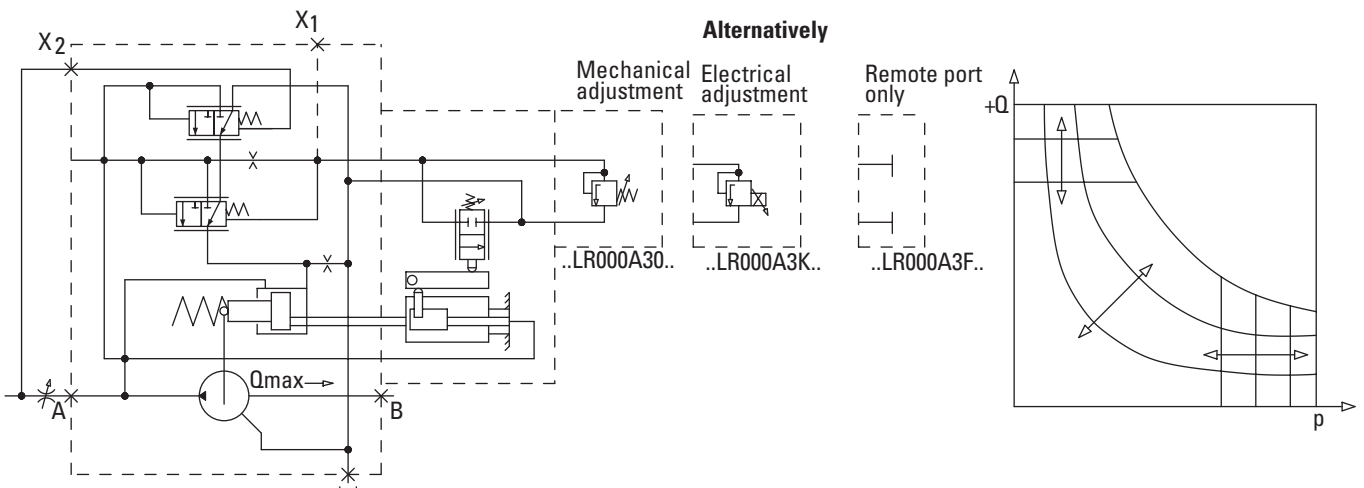

# Controls - DQ Mooring Control

"X" Series - Open loop pump

The DQ-control is a pressure control with overcenter operation (2 quadrants). It can be used eg. for counterbalanced systems or applications where reverse flow from the system can drive the pump in reverse (negative pump angle) such as a hydraulic motor.

The DQ-control is only available for sizes 66, (90 on request), 130 and 180 ccm/rev.

Like the standard Hydrokraft pressure compensator this control pilot operated and very stable. For performance data/response time please refer to the DF-control.

As an additional option the maximum (or minimum) flow can be limited by a spacer inside the control cylinder (position number. 13 in model coding, options 4, 5 or 6 in combination with customer adjustment specifications position 40-43 for the set values).

This solution is also recommended for very rough operating conditions and the need of a very exact repeatability over a long time period. The setting must be defined before ordering and cannot be modified during operation.

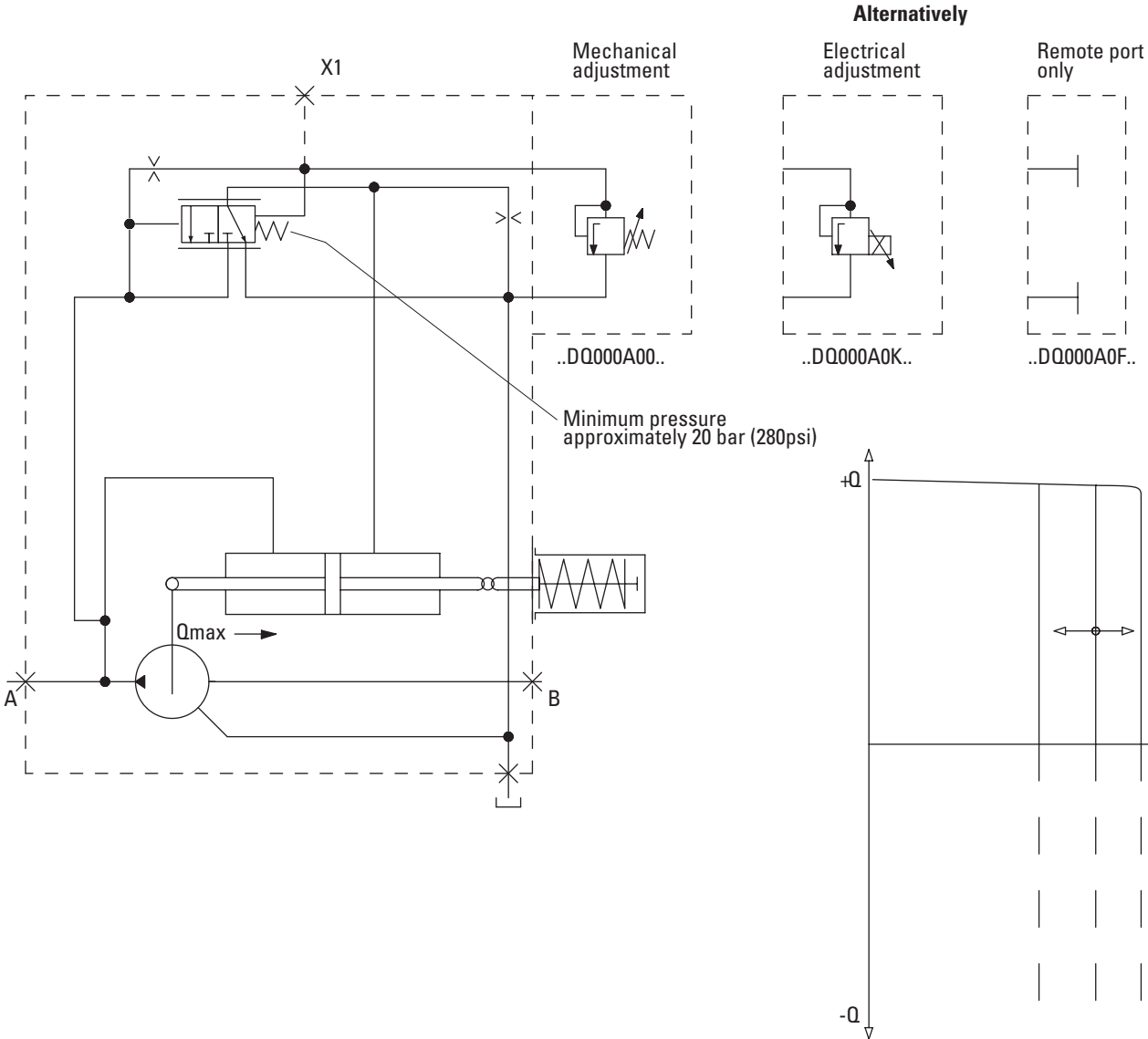

# Controls - HG Manual Adjustment Displacement Control FE

"X" Series - Open loop pump

**FE** The FE - control is a displacement control where the pump flow is adjusted by a screw.

**HG** The HG-control is a displacement control where the pump flow can be adjusted by a handwheel.

The maximum (and/or minimum) flow can be limited by a spacer inside the control cylinder (position number 13 in model coding, options 4, 5 or 6 in combination with

customer adjustment specifications position 40-43 for the set values). The setting must be defined before ordering and cannot be modified during operation.

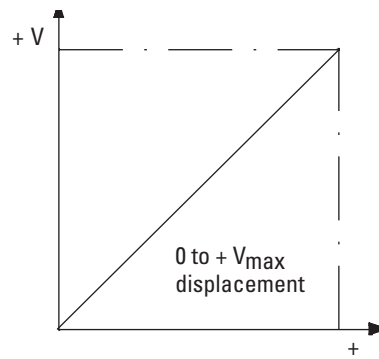
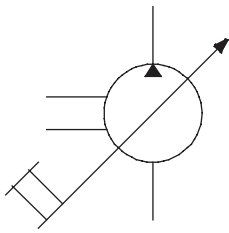

**Controls -  
Electric Motor  
Displacement  
Control ES**

"X" Series - Open loop pump

The unit is used for stepless adjustment. It has a three phase electric servo motor, worm gearing and a switch box with 4 and 8 limit switches for different positions. A potentiometer is also available.

The response times from zero to maximum depends on the chosen ration and the speed of the servo motor (this means that during operation the response times are not variable.

**No pressure/power limiter possible.**

Explosion protection versions are also available.

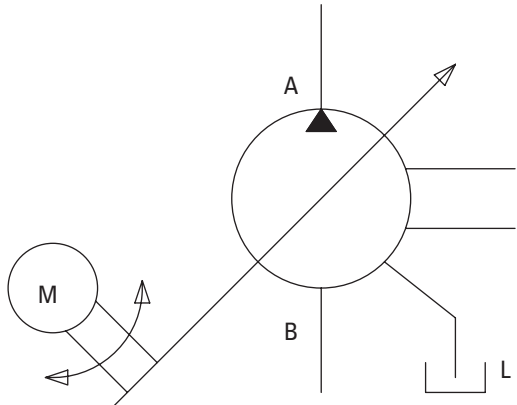
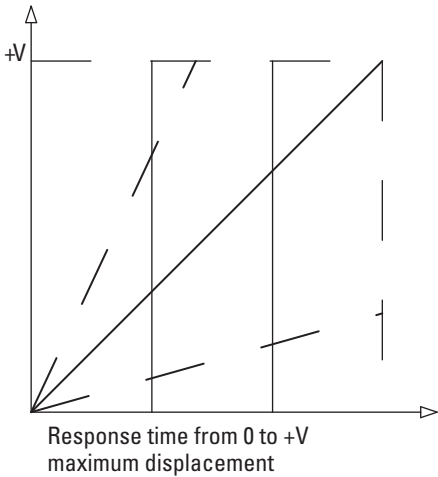
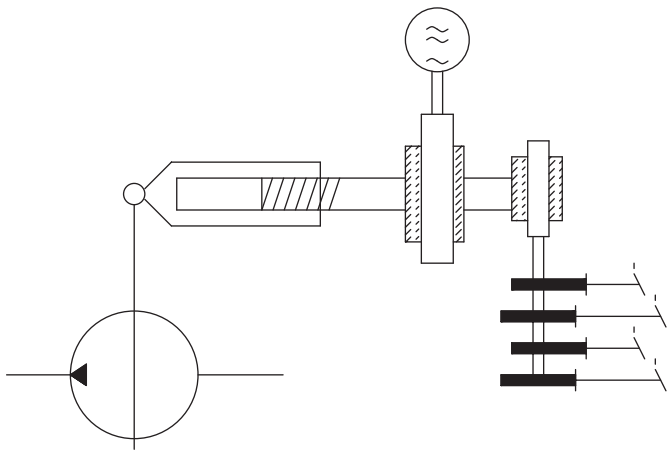

**ATUS-PVX Response Times ES - Control**

	THEORETICAL RESPONSE TIME (SEC) FOR MAX. DISPLACEMENT						CHARACTER IN MODEL CODE POS. 26
Size	066	090	130	180	250	250	
Freq. Hz	50	60	50	60	50	60	
Fast	7	6	18	15	15	13	M
Medium	24	20	35	29	30	25	N
Slow	38	32	54	45	48	40	P

Response time from 0 to +Q<sub>max</sub>

# Controls - Pressure Signal Displacement Control DP

"X" Series - Open loop pump

The output flow of the pump is proportional to the pilot pressure

A separate pilot oil circuit is necessary. From this the control pressure is reduced to the desired set value by means of a suitable pressure control valve (with P -T line ) and throttle in P - line 0.8 Ø (0.03 in).

The DP-control can be used for steepless flow control with standard requirements for dynamic and precision.

No feedback signal is needed, an optical indicator recommended (position 22 in model coding, option "V"). A pilot oil filter can be mounted in line between pump and control (position 35 in model coding, option "V" or "E").

Pressure limiter or power limiter override not available ( or such and other options please refer to PVW-Series ).

As an additional option the maximum (and/or minimum) flow can be limited by a spacer inside the control cylinder (position number 13 in model coding, options 4, 5 or 6 in combination with

customer adjustment specifications position 40-43 for the set values). This solution is also recommended for very rough operating conditions and the need of a very exact repeatability over a long time period. The setting must be defined before ordering and cannot be modified during operation.

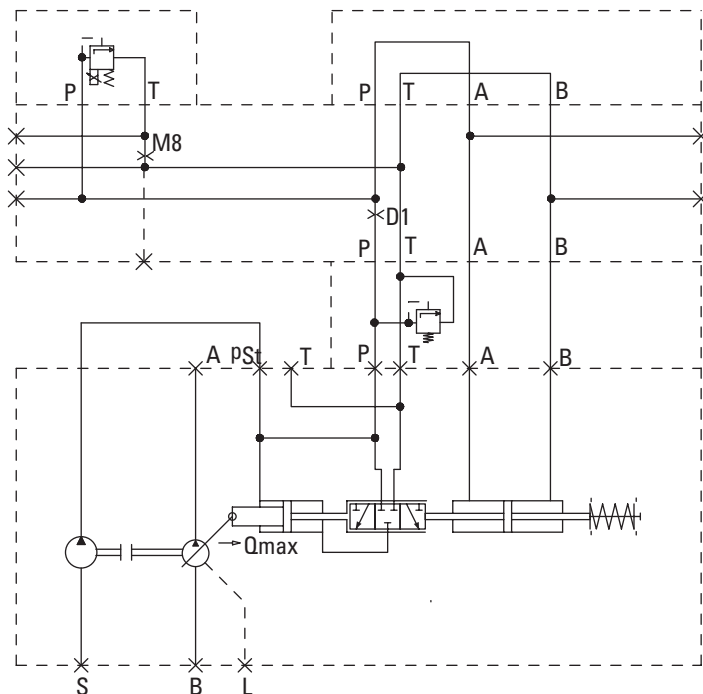

## ATUS-PVX Response Times DP - Control

SIZE	RESPONSE TIME (SEC)	
	W/ 12 L/MIN PILOT OIL FLOW (STANDARD)	PILOT PRESSURE P <sub>st</sub> BAR
066/090	0.7	60
130/180	0.9	60
250	1.1	60

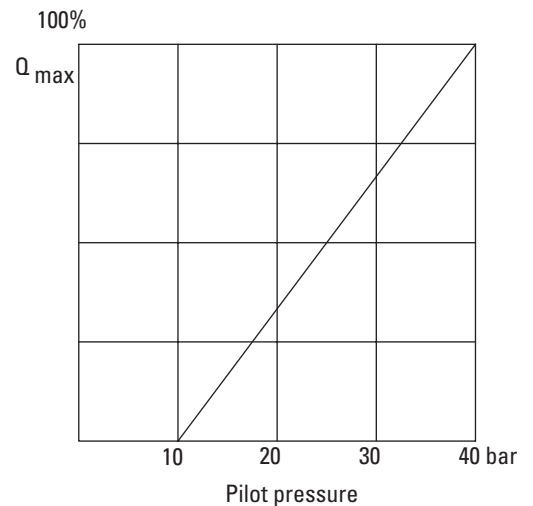

The output flow of the pump is proportional to the pilot pressure

## Controls - Proportional Valve Displacement Control SP

"X" Series - Open loop pump

The SP control operates a hydrostatic drive and works without throttle losses within electrically adjustable limits. This is done by controlling delivery flow with electrical swashplate angle feedback (electrally closed-loop control). All control values are recorded as an electrical signal and lead back to the control card.

The proportional valve and servo piston transform the output signal of the control card to the desired setting. This results in a very precise and dynamic control. Pressure limiter override available on request. Power limiter override not available (for such and other options please refer to ATUS-PVW series).

As an additional option the maximum (and/or minimum) flow can be limited by a spacer inside the control cylinder (position number 13 in model coding, options 4, 5 or 6 in combination with customer adjustment specifications position 40-43 for the set values).

This solution is also recommended for very rough operating conditions and the need of a very exact repeatability over a long time period. The setting must be defined before ordering and cannot be modified during operation.

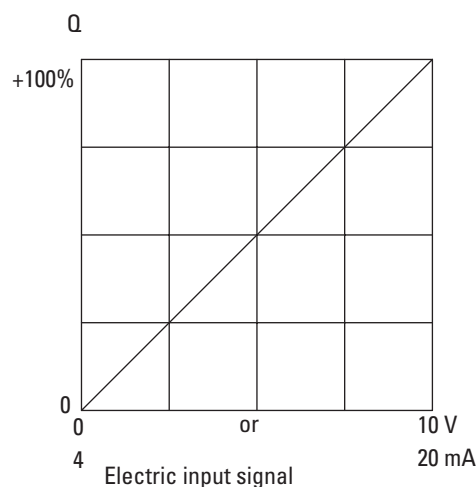
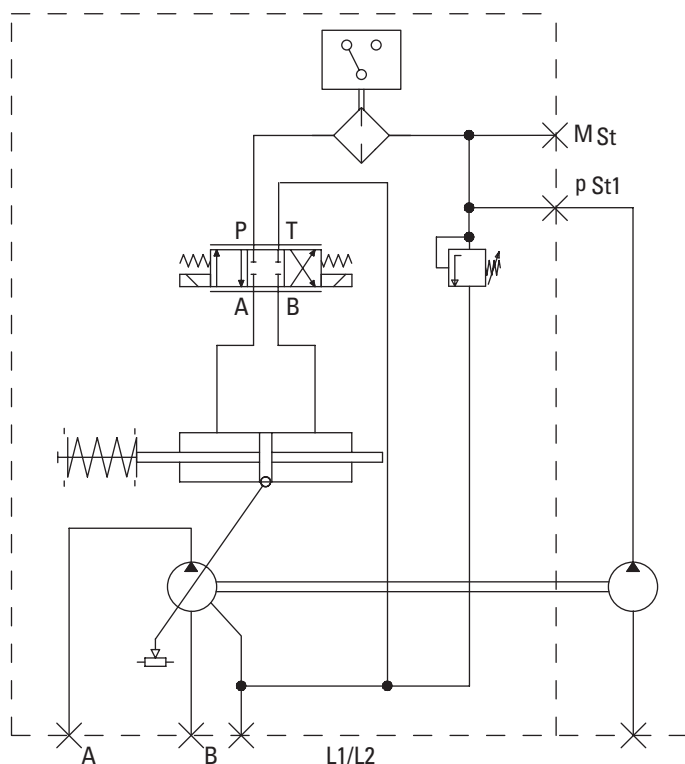

### ATUS-PVX RESPONSE TIMES SP - CONTROL

PROPORTIONAL VALVE	PILOT OIL FLOW	PILOT OIL PRESSURE $P_{ST}$	CONTROL ELECTRONICS (Amp. Card)	RESPONSE TIME	UNIT SIZE	SERVO PISTON		
	L/min (Us gpm)			$0 < > V_{max}$ [ms]		Diameter mm (in)	Stroke mm (in)	Volume cm <sup>3</sup> (in <sup>3</sup> )
Medium Response		60 (857)		250	066 / 090	40/30 (1.57/1.18)	28 (1.10)	15,4 (0.939)
KDG4V3-2C20NMUH760 (CETOP 3)	12 (3.17)	60 (857)	ER 9.3-10	350	130 / 180	55/38 (2.16/1.49)	35 (1.37)	43,5 (2.654)
High Response (CETOP 5)		60 (857)		550		70/50 (2.76/1.97)	43,5 (1.71)	81 (4.942)
					ON REQUEST			

The ER9.3-10 and ER 9.4-10 ( for High Response ) digital Amplifier cards are optimized for use with the SP-Control. Please ask for separate Documentation. Software is available for parameter setting and storing (database function). Contact ATUS to request free of charge manual - and software CD.

# Pump Dimensions - ATUS-PFXS 066

Dimensions in mm

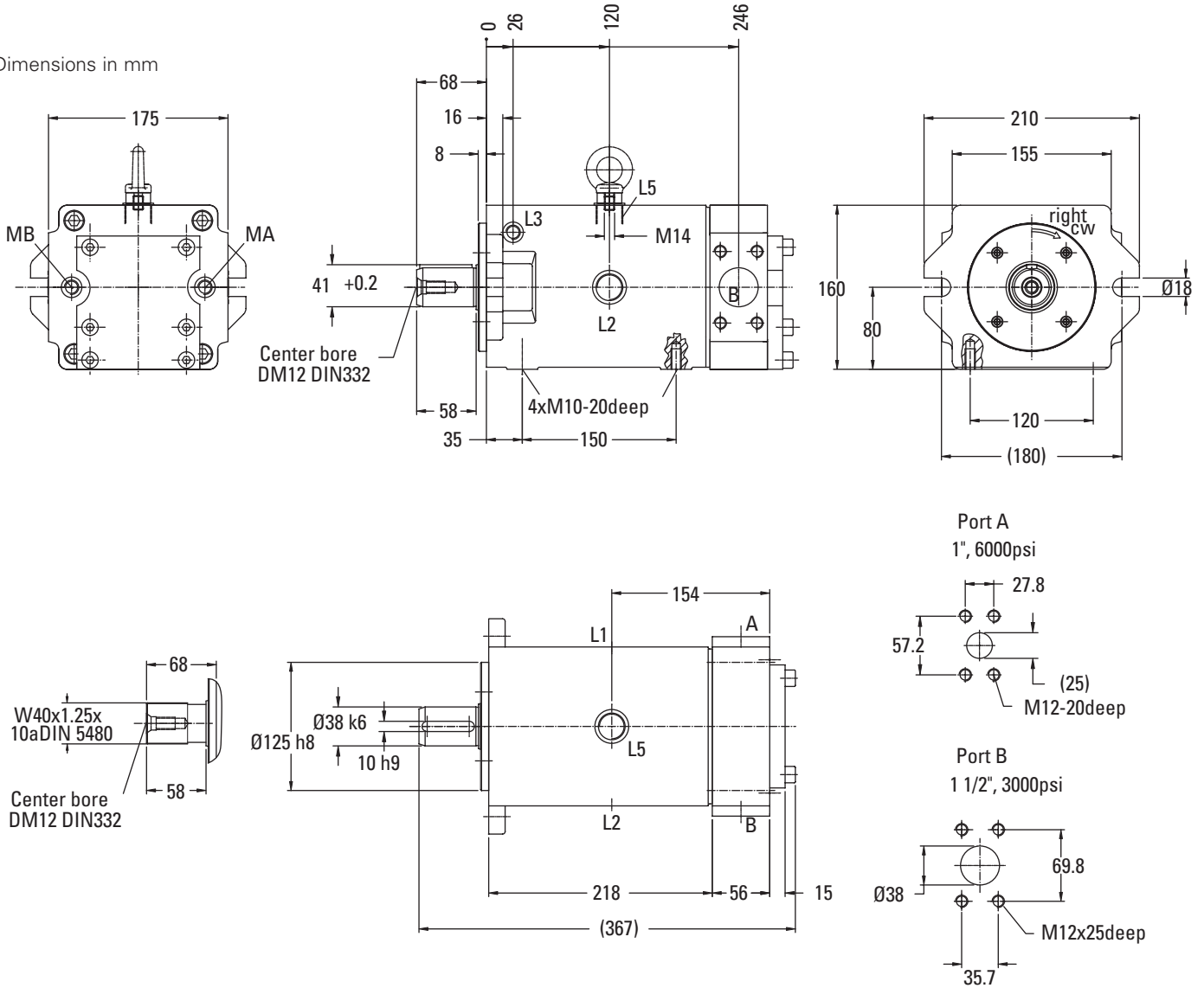

- A System pressure port SAE 1", 415 bar (6000 psi)
- B System pressure port SAE 1 1/2", 207 bar (3000 psi)
- (L1) Drain port 7/8" – 14 UNF
- (L2) Ventilation port for vertical mounting M26x1.5
- (L3) Ventilation port for vertical mounting G1/4" (shaft upwards)
- (L5) Oil filling plug M26x1.5
- (MA) Gauge port system pressure G1/4"
- (MB) Gauge port system pressure G1/4"
- (...) Normally plugged

Non-Standard Displacements:

Standard Displacement . . . . .66 ccm/rev  
Reduced Displacement Available . . . . .55 or 44 ccm/rev

DIRECTION OF ROTATION	INPUT	OUTPUT
Right Hand Rotation	B	A
Left Hand Rotation	A	B



Pump  
Dimensions -  
ATUS-PFXS 090

Dimensions in mm

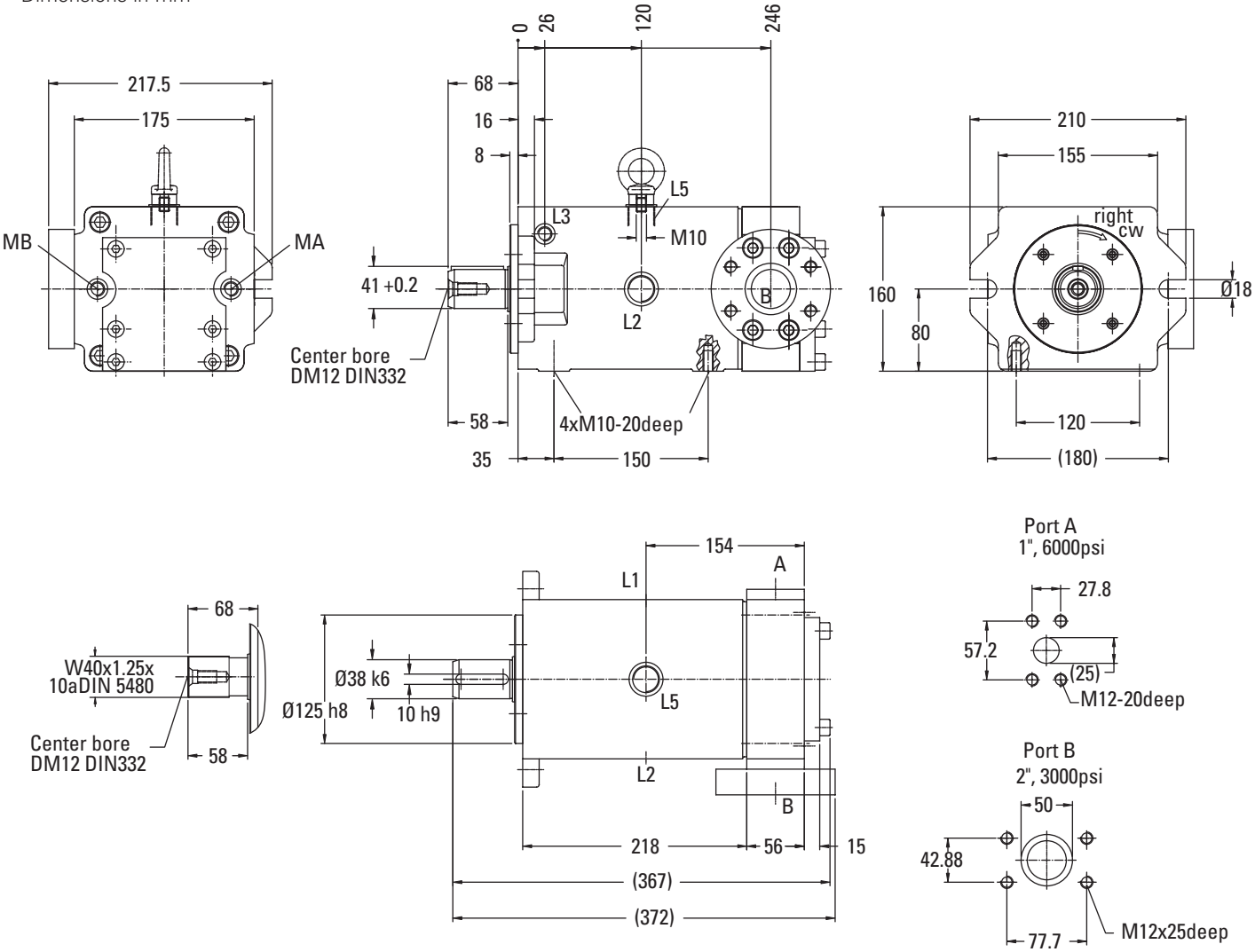

- A System pressure port SAE 1", 415 bar (6000 psi)
- B System pressure port SAE 2", 207 bar (3000 psi)
- (L1) Drain port 7/8" – 14 UNF
- (L2) Ventilation port for vertical mounting M26x1.5
- (L3) Ventilation port for vertical mounting G1/4 " (shaft upwards)
- (L5) Oil filling plug M26x1.5
- (MA) Gauge port system pressure G1/4"
- (MB) Gauge port system pressure G1/4"
- (...) Normally plugged

Non-Standard Displacements:  
Standard Displacement . . . . .90 ccm/rev  
Reduced Displacement Available . . . . .75 ccm/rev

DIRECTION OF ROTATION	INPUT	OUTPUT
Right Hand Rotation	B	A
Left Hand Rotation	A	B

# Pump Dimensions - ATUSPFXS 130

Dimensions in mm

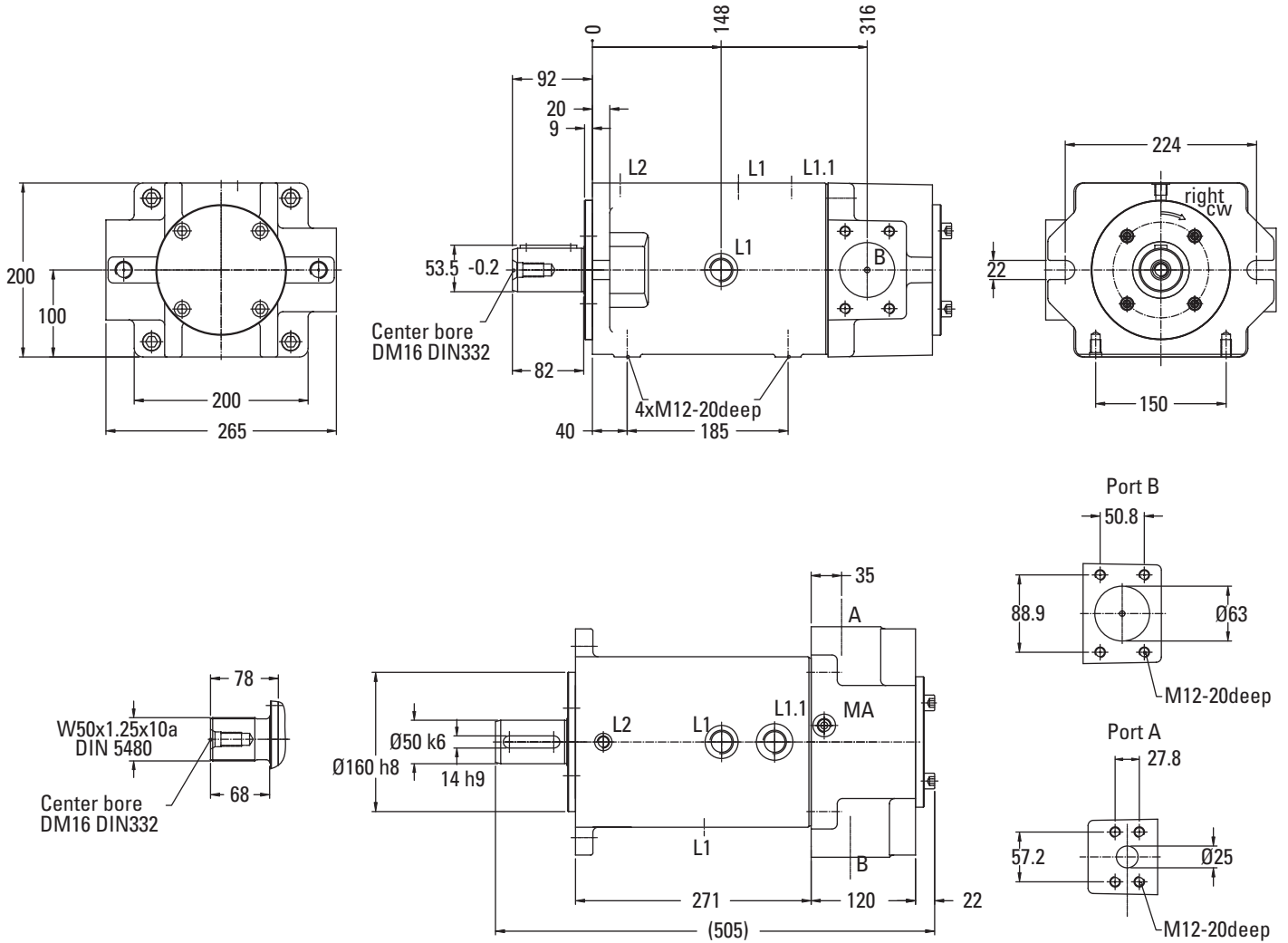

- A System pressure port SAE 1", 415 bar (6000 psi)
- B System pressure port SAE 2 1/2", 207 bar (3000 psi)
- (L1) Drain port M26x1.5
- (L1.1) Oil filling plug 1 1/16"-12UNF
- (L2) Ventilation port for vertical mounting G1/4"
- (MA) Gauge port system pressure G1/4"
- (...) normally plugged

#### Non-Standard Displacements:

Standard Displacement size 130.....130 ccm/rev  
 Reduced Displacement Available Size 130...115 or 94 ccm/rev

DIRECTION OF ROTATION	INPUT	OUTPUT
Right Hand Rotation	B	A
Left Hand Rotation	A	B

Pump  
Dimensions -  
ATUS-PFXS 180

Dimensions in mm

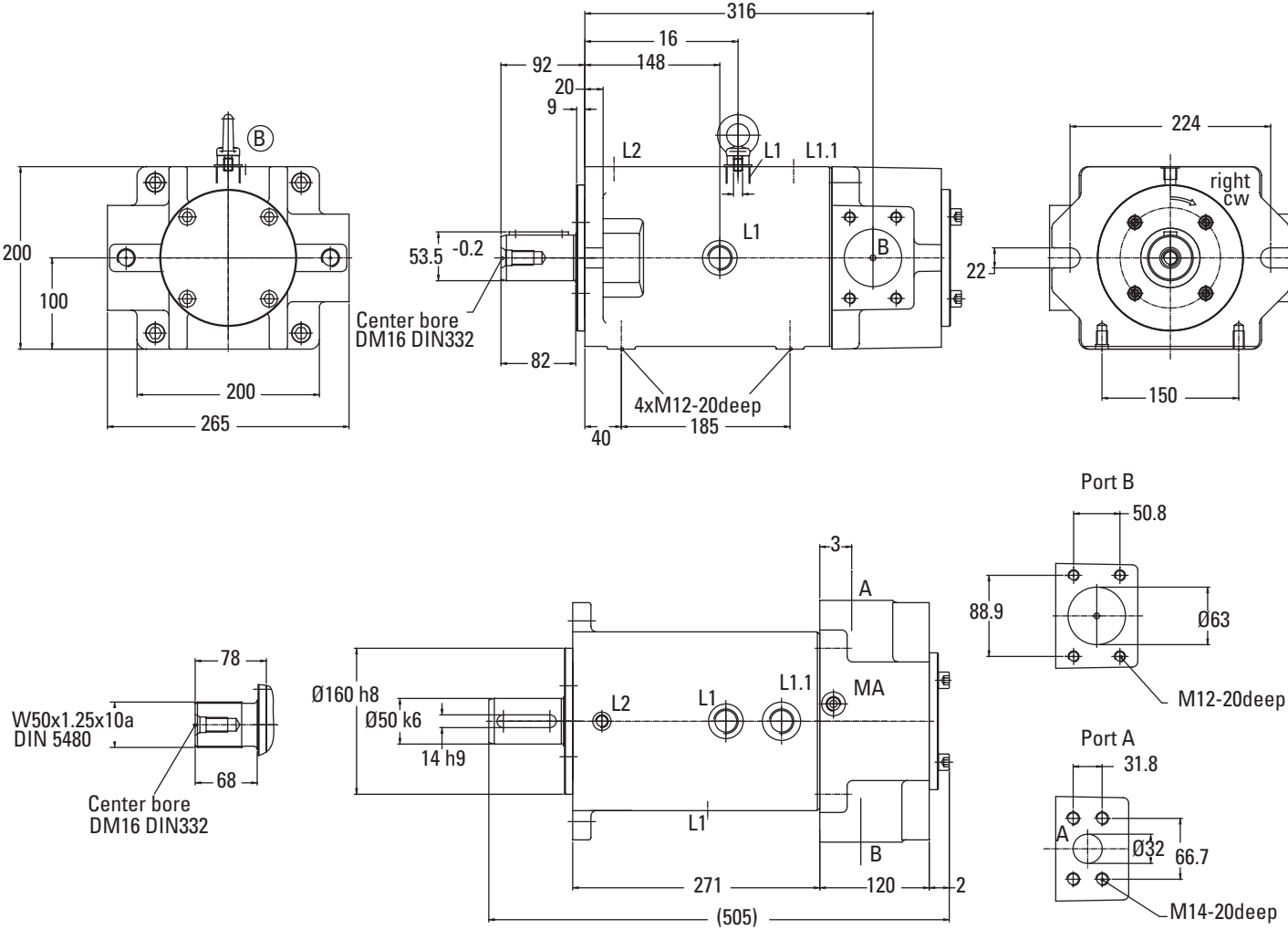

- A System pressure port SAE 1 1/4", 415 bar (6000 psi)
- B System pressure port SAE 2 1/2", 207 bar (3000 psi)
- (L1) Drain port M26x1.5
- (L1.1) Oil filling plug 1 1/16"-12UNF
- (L2) Ventilation port for vertical mounting G1/4"
- (MA) Gauge port system pressure G1/4"
- (...) Normally plugged

Non-Standard Displacements:  
 Standard Displacement Size 180 .....180 ccm/rev  
 Reduced Displacement Available Size 180.....160 ccm/rev

DIRECTION OF ROTATION	INPUT	OUTPUT
Right Hand Rotation	B	A
Left Hand Rotation	A	B

# Pump Dimensions - ATUS-PFXS 250

Dimensions in mm

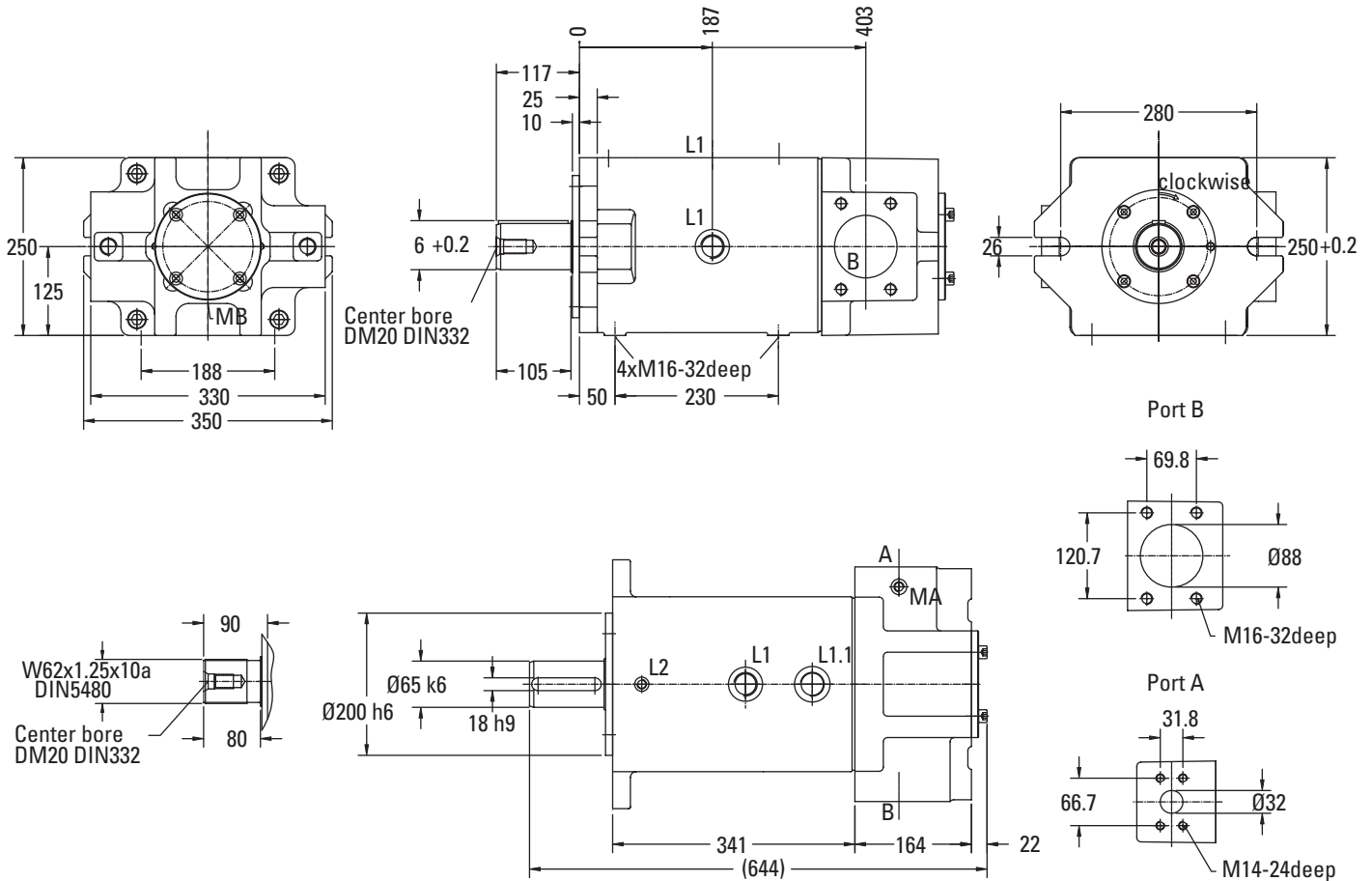

- A System pressure port SAE 1 1/4", 415 bar (6000 psi)
- B System pressure port SAE 3 1/2", 35 bar (500 psi)
- (L1) Drain port M26x1.5
- (L1.1) Oil filling plug 1 5/16"-12UN
- (L2) Ventilation port for vertical mounting G1/4"
- (MA) Gauge port system pressure G1/4"
- (...) normally plugged

Non-Standard Displacements:

Standard Displacement .....250 ccm/rev  
 Reduced Displacement Available.....222, 208 or 194 ccm/rev

DIRECTION OF ROTATION	INPUT	OUTPUT
Right Hand Rotation	B	A
Left Hand Rotation	A	B



# Pump Dimensions - ATUS-PVXS 066 - 250 DF, Two Stage Pilot Valve

## Side ports - Pressure compensator DF000A ...

1. Pilot valve (2nd Stage)
2. Pressure compensator (1st stage)

Dimensions in mm

- X1 G1/4"x12,5-deep; option for an additional pilot valve and/or discharge valve of the pressure compensator
- L1 Two drain ports, one supplied plugged
- L2 M18x1, 5x12-deep supplementary drain, or bleed plug. Must be drained in addition to if the pump is installed with the shaft input end pointing upwards.
- MA G1/4"x12.5-deep gauge port supplied plugged

View X  
Port "A"  
6000psi

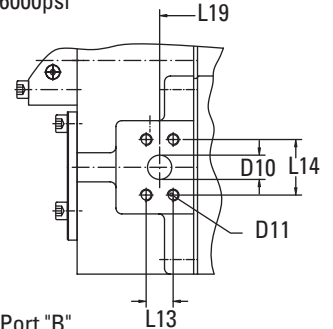

Port "B"  
3000/500psi

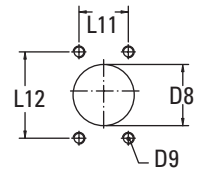

DIRECTION OF ROTATION	CONTROL	INPUT	OUTPUT
Right Hand Rotation	To + Vmax	B	A
	To - Vmax	A	B
Left Hand Rotation	To + Vmax	A	B
	To - Vmax	B	A

SIZE	SAE-FLANGE "B" 3000(500)PSI, INLET	SAE-FLANGE "A" 6000PSI, OUTLET	WEIGHT KG
066	1 1/2"	1"	55
090	2"	1"	57
130	2 1/2"	1"	111
180	2 1/2"	1 1/4"	113
250	3 1/2"	1 1/4"	226

SIZE	B1	B2	B3	B4	B5	B6	B7 h9	B8	B9	B10	B11	B12
066	210	116	160	235	130	180	10	116	58	185	218	—
090	210	116	160	235	130	180	10	116	58	185	218	157.5
130	260	140	200	265	224	224	14	140	70	185	218	—
180	260	140	200	265	224	224	14	140	70	185	218	—
250	325	175	250	330	280	280	18	175	87.5	185	218	—

SIZE	D1 h8	D2 k6	D3	D4	D5	D6 Light Execution	D7 DEEP	D8	D9 DEEP	D10	D11 DEEP	D12	D13 SAE 475
066	125	38	M12	18	M8	M22x1.5	M10 24	38	M12 24	25	M12 21	—	7/8-14UNF
090	125	38	M12	18	M8	M22x1.5	M10 20	50	M12 24	25	M12 21	—	7/8-14UNF
130	160	50	M16	22	M10	M26x1.5	M12 20	62	M12 20	25	M12 20	M20	1 1/16-12UNF
180	160	50	M16	22	M10	M26x1.5	M12 20	62	M12 20	32	M14 20	M20	1 1/16-12UNF
250	200	65	M20	26	M12	M33x2	M16 32	90	M16 32	32	M14 24	M24	1 5/16-12UNF

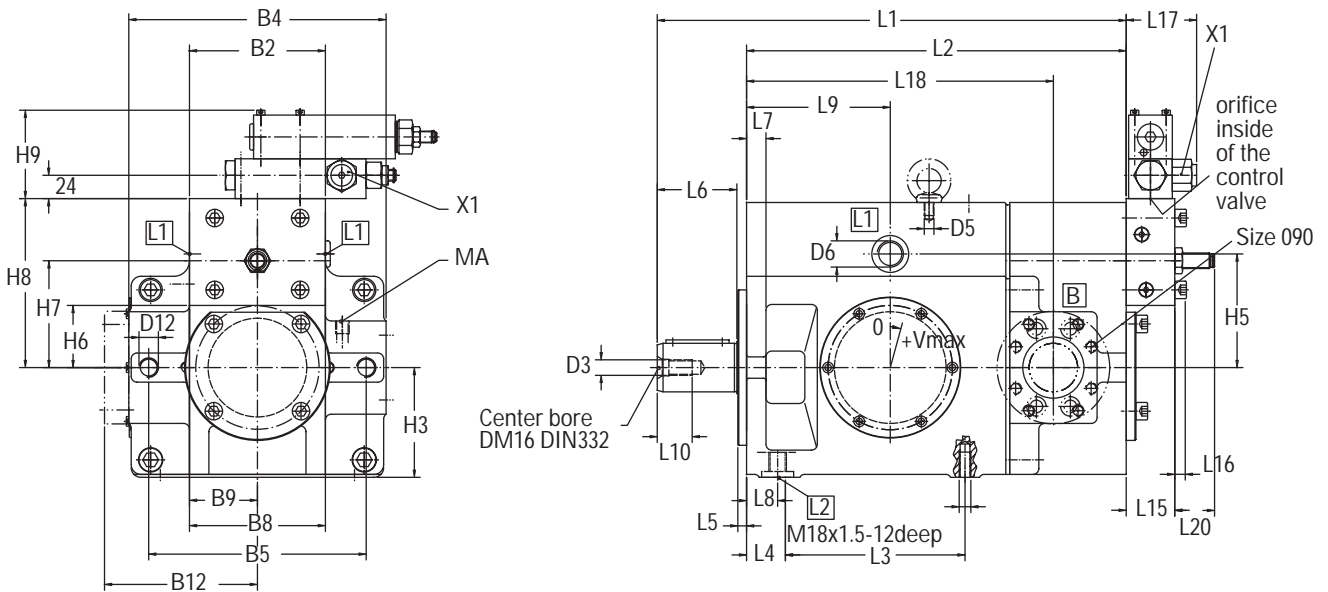

Splined shaft  
Dim. See page 51

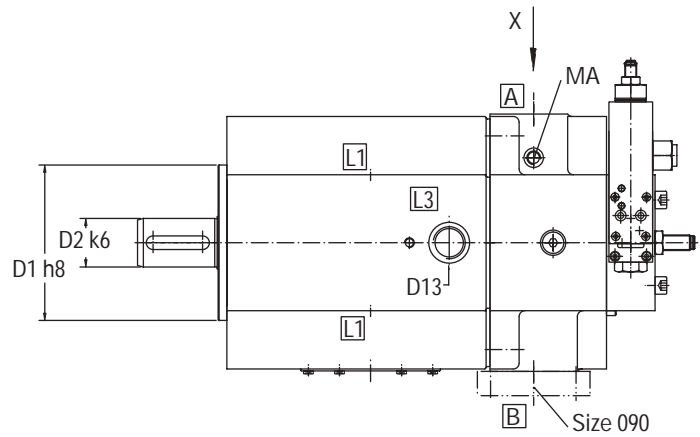
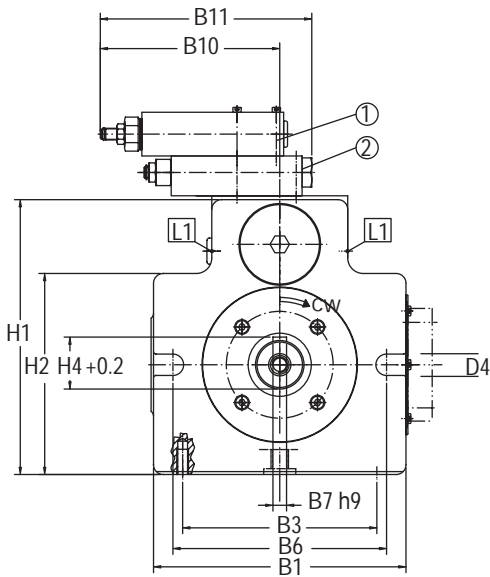

SIZE	H1	H2	H3	H4 +0.2	H5	H6	H7	H8	H9
066	227	162	90	41	93	53	88	139	91
090	227	162	90	41	93	53	88	139	91
130	283	207	113	53.5	117	64	110	174	91
180	283	207	113	53.5	117	64	110	174	91
250	354	260	140	69	146	77	138	217	91

SIZE	L1	L2	L3	L4	L5	L6	L7	L8	L9	L10	L11	L12	L13	L14	L15	L16	L17	L18	L19	L20
066	342	274	150	35	8	58	16	26	120	28	35.7	69.8	27.8	57.2	50	10	72.5	245.6	245.6	31
090	342	274	150	35	8	58	16	26	120	28	42.88	77.77	27.8	57.2	50	10	72.5	245.6	245.6	31
130	483	391	185	40	9	82	20	32	148	36	50.8	89	27.8	57.2	50	12	72.5	316	309	33
180	483	391	185	40	9	82	20	32	148	36	50.8	89	31.8	66.7	50	12	72.5	316	309	33
250	622	505	230	50	10	105	25	41	187	42	69.8	120.7	31.8	66.7	56	—	72.5	403	403	35

# Pump Dimensions - ATUS-PVXS 066 - 250 DF, with Load Sensing Valve

## Side ports - Pressure compensator with Load Sensing DF000A1 ...

1. Pilot valve (2nd Stage)
2. Pressure compensator (1st stage)
3. Flow valve

Dimensions in mm

- X1 G1/4"x12,5-deep; option for an additional pilot valve and/or discharge valve of the pressure compensator
- X2 G1/4"x12,5-deep; load sensing pilot port
- L1 Two drain ports, one supplied plugged
- L2 M18x1, 5x12-deep supplementary drain, or bleed plug. Must be drained in addition to if the pump is installed with the shaft input end pointing upwards.
- MA G1/4"x12.5-deep gauge port supplied plugged

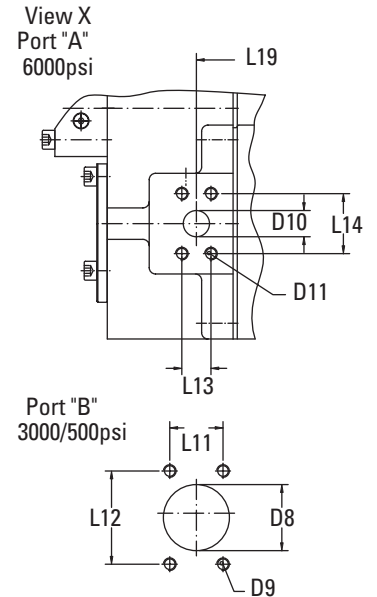

DIRECTION OF ROTATION	CONTROL	INPUT	OUTPUT
Right Hand Rotation	To + Vmax	B	A
	To - Vmax	A	B
Left Hand Rotation	To + Vmax	A	B
	To - Vmax	B	A

SIZE	SAE-FLANGE "B" 3000(500)PSI, INLET	SAE-FLANGE "A" 6000PSI, OUTLET	WEIGHT KG
066	1 1/2"	1"	55
090	2"	1"	57
130	2 1/2"	1"	111
180	2 1/2"	1 1/4"	113
250	3 1/2"	1 1/4"	226

SIZE	B1	B2	B3	B4	B5	B6	B7 h9	B8	B9	B10	B11	B12
066	210	116	160	235	130	180	10	116	58	185	218	—
090	210	116	160	235	130	180	10	116	58	185	218	157.5
130	260	140	200	265	224	224	14	140	70	185	218	—
180	260	140	200	265	224	224	14	140	70	185	218	—
250	325	175	250	330	280	280	18	175	87.5	185	218	—

SIZE	D1 h8	D2 k6	D3	D4	D5	D6 Light Execution	D7	DEEP	D8	D9	DEEP	D10	D11	DEEP	D12	D13 SAE 475
066	125	38	M12	18	M8	M22x1.5	M10	24	38	M12	24	25	M12	21	—	7/8-14UNF
090	125	38	M12	18	M8	M22x1.5	M10	20	50	M12	24	25	M12	21	—	7/8-14UNF
130	160	50	M16	22	M10	M26x1.5	M12	20	62	M12	20	25	M12	20	M20	1 1/16-12UNF
180	160	50	M16	22	M10	M26x1.5	M12	20	62	M12	20	32	M14	20	M20	1 1/16-12UNF
250	200	65	M20	26	M12	M33x2	M16	32	90	M16	32	32	M14	24	M24	1 5/16-12UNF



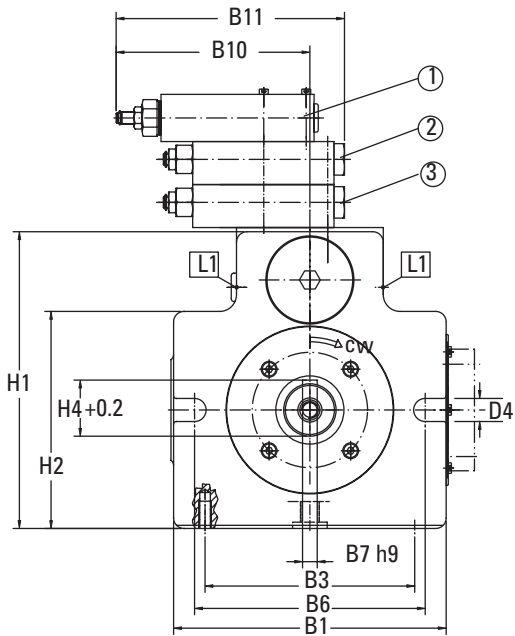
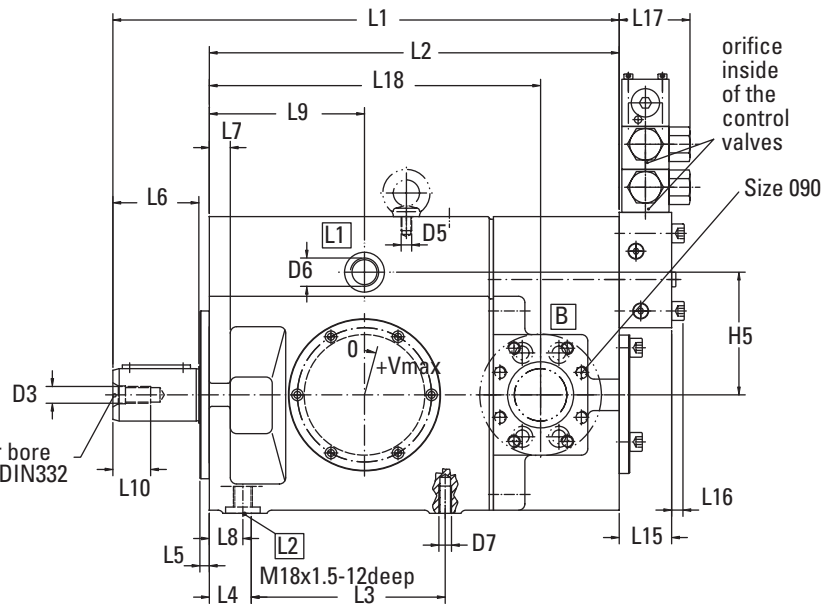
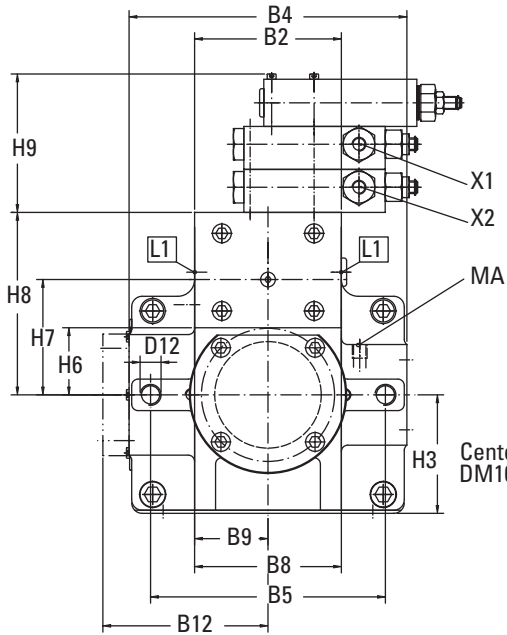

**Splined shaft**  
Dim. See page 51

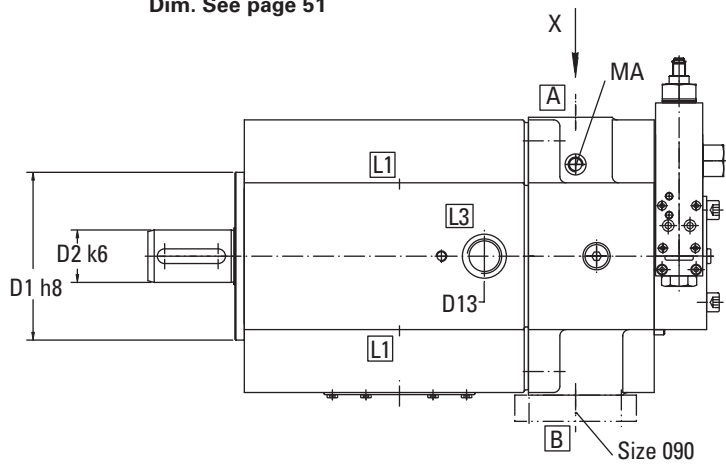

SIZE	H1	H2	H3	H4 +0.2	H5	H6	H7	H8	H9
066	227	162	90	41	93	53	88	139	132
090	227	162	90	41	93	53	88	139	132
130	283	207	113	53.5	117	64	110	174	132
180	283	207	113	53.5	117	64	110	174	132
250	354	260	140	69	146	77	138	217	132

SIZE	L1	L2	L3	L4	L5	L6	L7	L8	L9	L10	L11	L12	L13	L14	L15	L16	L17	L18	L19
066	342	274	150	35	8	58	16	26	120	28	35.7	69.8	27.8	57.2	50	10	67.5	245.6	245.6
090	342	274	150	35	8	58	16	26	120	28	42.88	77.77	27.8	57.2	50	10	67.5	245.6	245.6
130	483	391	185	40	9	82	20	32	148	36	50.8	89	27.8	57.2	50	12	67.5	316	306
180	483	391	185	40	9	82	20	32	148	36	50.8	89	31.8	66.7	50	12	67.5	316	306
250	622	505	230	50	10	105	25	41	187	42	69.8	120.7	31.8	66.7	56	—	70.5	403	403

# Pump Dimensions - ATUS-PVXS 066 - 250 LR, with Pressure Limiter

## Side ports - Power Control LR (with pressure limiter) LR000A2 ...

1. Pilot valve (2nd Stage)
2. Pressure compensator (1st stage)
3. Constant power control

Dimensions in mm

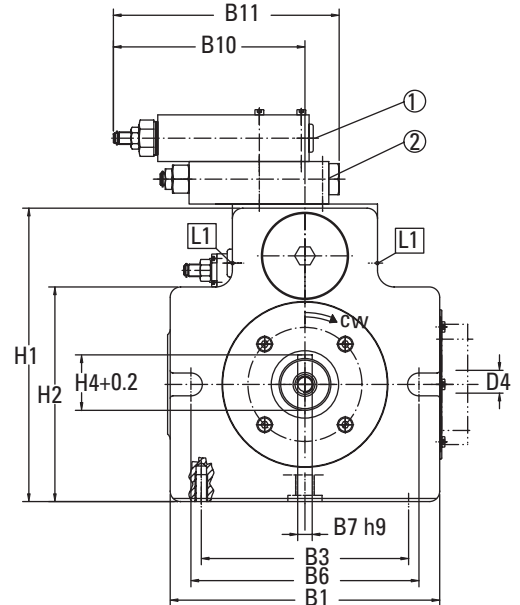

- ⊠1 G1/4"x12,5-deep; option for an additional pilot valve and/or discharge valve of the pressure compensator
- ⊠L1 Two drain ports, one supplied plugged
- ⊠L2 M18x1, 5x12-deep supplementary drain, or bleed plug. Must be drained in addition to if the pump is installed with the shaft input end pointing upwards.
- ⊠MA G1/4"x12.5-deep gauge port supplied plugged

DIRECTION OF ROTATION	CONTROL	INPUT	OUTPUT
Right Hand Rotation	To + Vmax	B	A
	To - Vmax	A	B
Left Hand Rotation	To + Vmax	A	B
	To - Vmax	B	A

SIZE	SAE-FLANGE "B" 3000(500)PSI, INLET	SAE-FLANGE "A" 6000PSI, OUTLET	WEIGHT KG
066	1 1/2"	1"	55
090	2"	1"	57
130	2 1/2"	1"	111
180	2 1/2"	1 1/4"	113
250	3 1/2"	1 1/4"	226

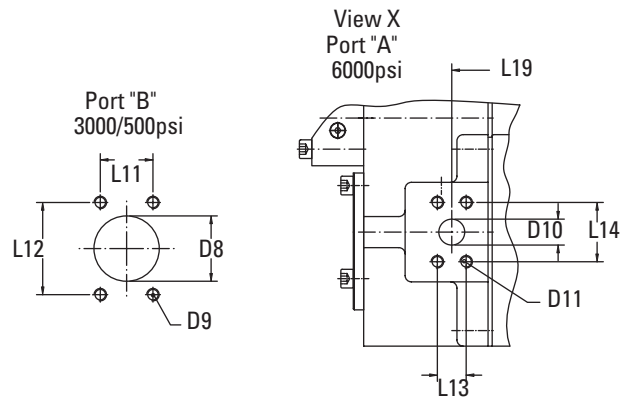

SIZE	B1	B2	B3	B4	B5	B6	B7 h9	B8	B9	B10	B11	B12
066	210	116	160	235	130	180	10	116	58	185	218	—
090	210	116	160	235	130	180	10	116	58	185	218	157.5
130	260	140	200	265	224	224	14	140	70	185	218	—
180	260	140	200	265	224	224	14	140	70	185	218	—
250	325	175	250	330	280	280	18	175	87.5	185	218	—

SIZE	D1 h8	D2 k6	D3	D4	D5	D6 Light Execution	D7	DEEP	D8	D9	DEEP	D10	D11	DEEP	D12	D13 SAE 475
066	125	38	M12	18	M8	M22x1.5	M10	24	38	M12	24	25	M12	21	—	7/8-14UNF
090	125	38	M12	18	M8	M22x1.5	M10	20	50	M12	24	25	M12	21	—	7/8-14UNF
130	160	50	M16	22	M10	M26x1.5	M12	20	62	M12	20	25	M12	20	M20	1 1/16-12UNF
180	160	50	M16	22	M10	M26x1.5	M12	20	62	M12	20	32	M14	20	M20	1 1/16-12UNF
250	200	65	M20	26	M12	M33x2	M16	32	90	M16	32	32	M14	24	M24	1 5/16-12UNF

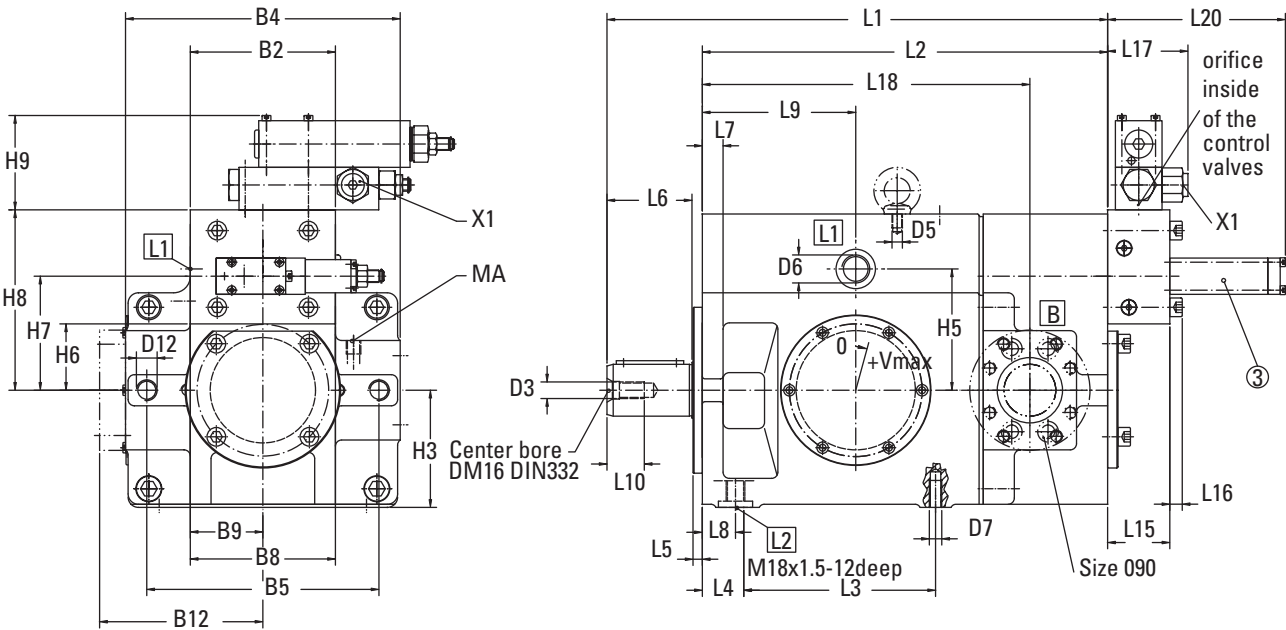

Splined shaft  
Dim. See page 51

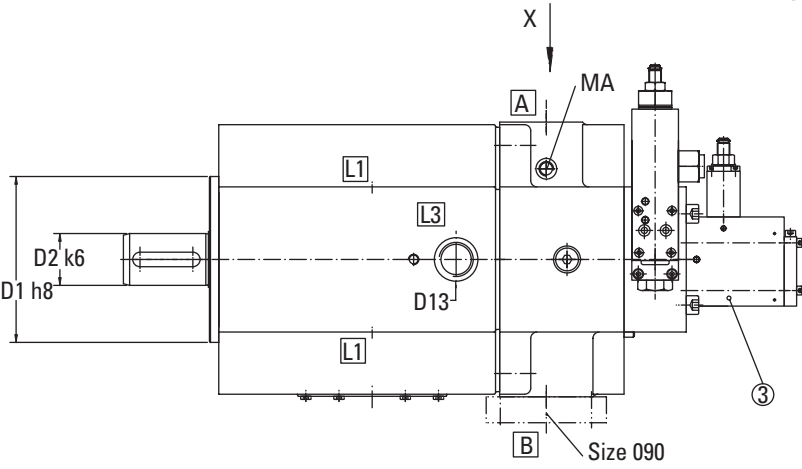

SIZE	H1	H2	H3	H4 +0.2	H5	H6	H7	H8	H9
066	227	162	90	41	93	53	88	139	91
090	227	162	90	41	93	53	88	139	91
130	283	207	113	53.5	117	64	110	174	91
180	283	207	113	53.5	117	64	110	174	91
250	354	260	140	69	146	77	138	217	91

SIZE	L1	L2	L3	L4	L5	L6	L7	L8	L9	L10	L11	L12	L13	L14	L15	L16	L17	L18	L19	L20
066	342	274	150	35	8	58	16	26	120	28	35.7	69.8	27.8	57.2	50	10	72.5	245.6	245.6	161
090	342	274	150	35	8	58	16	26	120	28	42.88	77.77	27.8	57.2	50	10	72.5	245.6	245.6	161
130	483	391	185	40	9	82	20	32	148	36	50.8	89	27.8	57.2	60	12	72.5	316	306	171
180	483	391	185	40	9	82	20	32	148	36	50.8	89	31.8	66.7	60	12	72.5	316	306	171
250	622	505	230	50	10	105	25	41	187	42	69.8	120.7	31.8	66.7	112	—	75.5	403	403	199.5

# Pump Dimensions - ATUS-PVXS 066 - 250 ES

Side ports -  
Electric Motor  
Displacement Control  
ES\*00A ...

Dimensions in mm

- L1 Two drain ports, one supplied plugged
- L2 M18x1, 5x12-deep supplementary drain, or bleed plug. Must be drained in addition to if the pump is installed with the shaft input end pointing upwards.
- MA G1/4"x12.5-deep gauge port supplied plugged

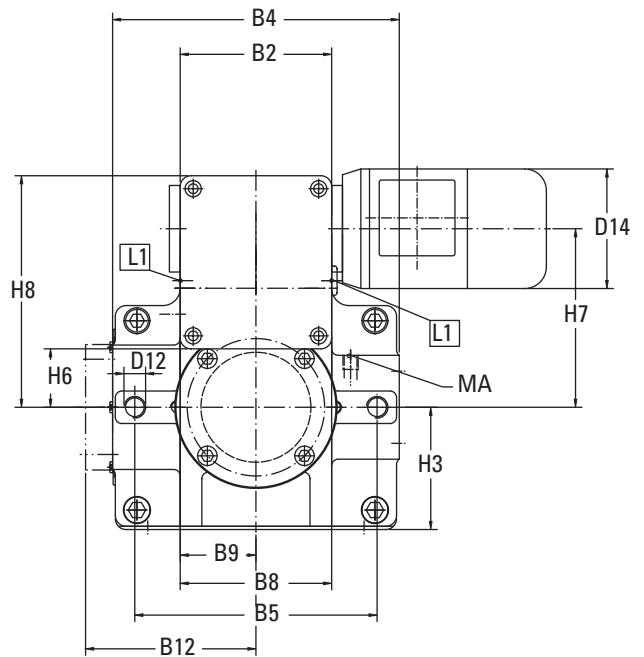

DIRECTION OF ROTATION	CONTROL	INPUT	OUTPUT
Right Hand Rotation	To + Vmax	B	A
	To - Vmax	A	B
Left Hand Rotation	To + Vmax	A	B
	To - Vmax	B	A

SIZE	SAE-FLANGE "B" 3000(500)PSI, INLET	SAE-FLANGE "A" 6000PSI, OUTLET	WEIGHT KG
066	1 1/2"	1"	55
090	2"	1"	57
130	2 1/2"	1"	111
180	2 1/2"	1 1/4"	113
250	3 1/2"	1 1/4"	226

SIZE	B1	B2	B3	B4	B5	B6	B7 h9	B8	B9	B10	B11	B12
066	210	116	160	235	130	180	10	116	58	276.5	334.5	—
090	210	116	160	235	130	180	10	116	58	276.5	334.5	157.5
130	260	140	200	265	224	224	14	140	70	288.5	368.5	—
180	260	140	200	265	224	224	14	140	70	288.5	368.5	—
250	325	180	250	330	280	280	18	175	87.5	332.7	434.7	—

SIZE	D1 h8	D2 k6	D3	D4	D5	D6 Light Execution	D7 DEEP	D8	D9 DEEP	D10	D11 DEEP	D12	D13 SAE 475	D14
066	125	38	M12	18	M8	M22x1.5	M10 24	38	M12 24	25	M12 21	—	7/8-14UNF	110.5
090	125	38	M12	18	M8	M22x1.5	M10 20	50	M12 24	25	M12 21	—	7/8-14UNF	110.5
130	160	50	M16	22	M10	M26x1.5	M12 20	62	M12 20	25	M12 20	M20	1 1/16-12UNF	110.5
180	160	50	M16	22	M10	M26x1.5	M12 20	62	M12 20	32	M14 20	M20	1 1/16-12UNF	110.5
250	200	65	M20	26	M12	M33x2	M16 32	90	M16 32	32	M14 24	M24	1 5/16-12UNF	123

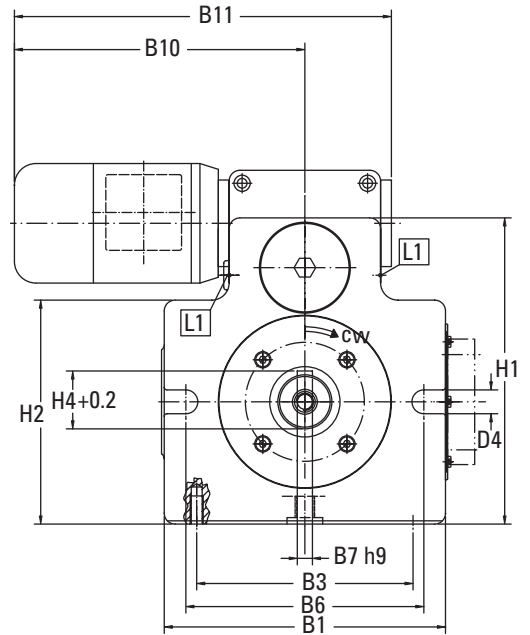
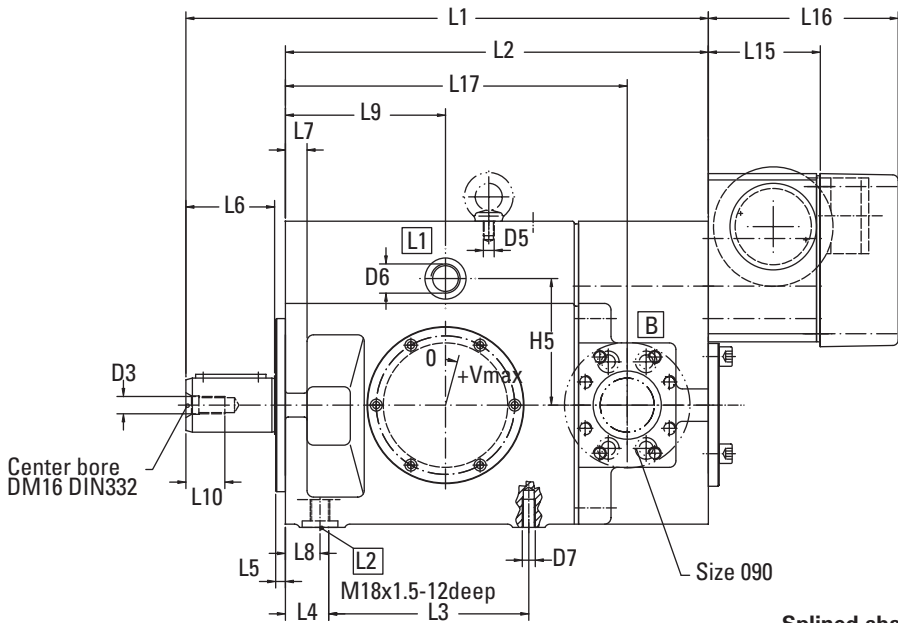

Splined shaft  
Dim. See page 51

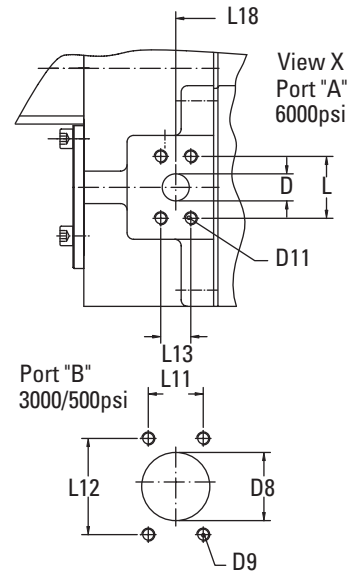
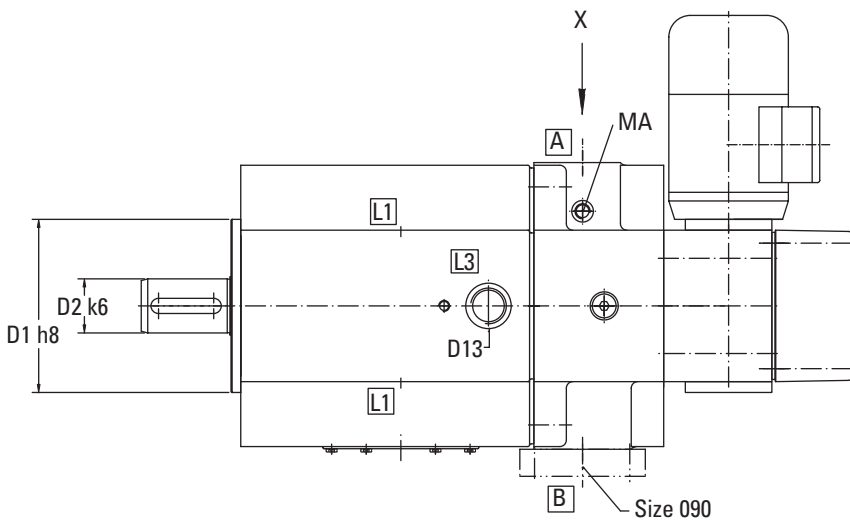

SIZE	H1	H2	H3	H4 +0.2	H5	H6	H7	H8
066	227	162	90	41	93	53	122	168
090	227	162	90	41	93	53	122	168
130	283	207	113	53.5	117	58.5	165	214
180	283	207	113	53.5	117	58.5	165	214
250	354	260	140	69	146	77	198	262

SIZE	L1	L2	L3	L4	L5	L6	L7	L8	L9	L10	L11	L12	L13	L14	L15	L16	L17	L18
066	342	274	150	35	8	58	16	26	120	28	35.7	69.8	27.8	57.2	78	153.5	7245.6	245.6
090	342	274	150	35	8	58	16	26	120	28	42.88	77.77	27.8	57.2	78	153.5	245.6	245.6
130	483	391	185	40	9	82	20	32	148	36	50.8	89	27.8	57.2	100	175.5	316	306
180	483	391	185	40	9	82	20	32	148	36	50.8	89	31.8	66.7	100	175.5	316	306
250	622	505	230	50	10	105	25	41	187	42	69.8	120.7	31.8	66.7	88	163.5	403	403

# Pump Dimensions - ATUS-PVXS 066 - 250

## Side ports - Pressure Signal Displacement Control DP\*00A ...

1. Pressure proportional valve
2. Pressure limiter

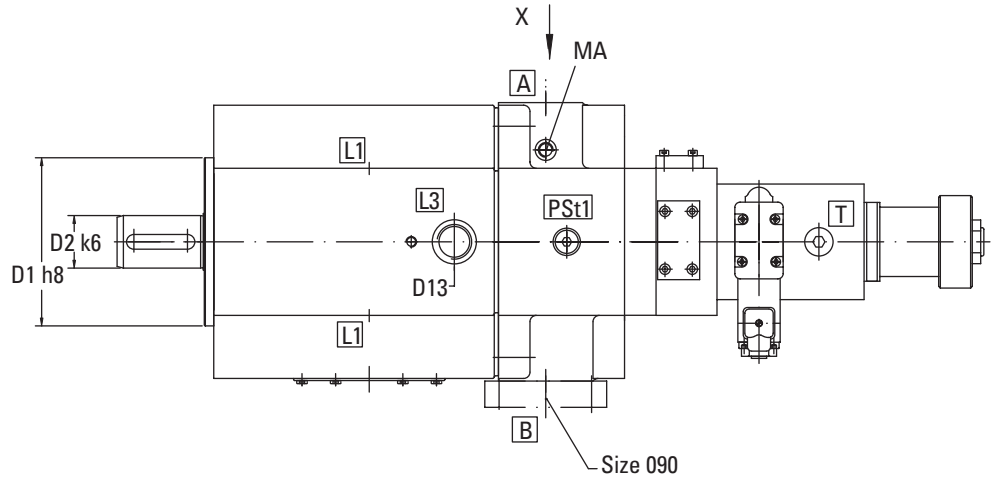

Dimensions in mm

- T G1/2" Tank port
- SS1 G3/4" Suction port of pilot pump
- PS1 G3/4" Port of pilot pressure
- PSt1 Port of pilot pressure Size 006/090=M14x1.5  
Size 130/180=M16x1.5  
Size 250=G1/2"(M22x1.5)
- L1 Two drain ports, one supplied plugged
- L2 M18x1, 5x12-deep supplementary drain, or bleed plug.  
Must be drained in addition to if the pump is installed  
with the shaft input end pointing upwards.
- MA G1/4"x12.5-deep gauge port supplied plugged

**Splined shaft**  
Dim. See page 51

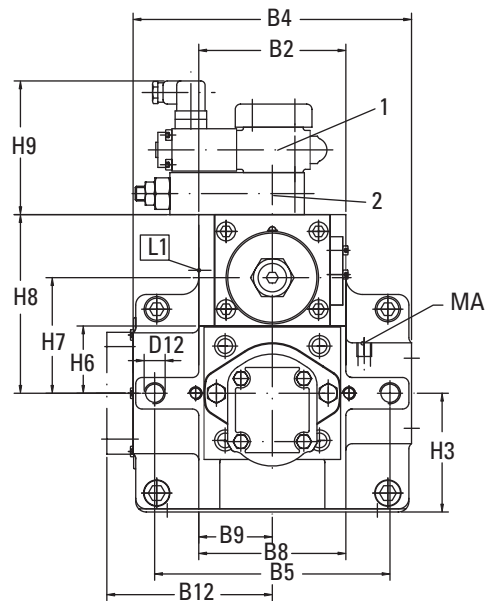

DIRECTION OF ROTATION	CONTROL	INPUT	OUTPUT
Right Hand Rotation	To + Vmax	B	A
	To - Vmax	A	B
Left Hand Rotation	To + Vmax	A	B
	To - Vmax	B	A

SIZE	SAE-FLANGE "B" 3000(500)PSI, INLET	SAE-FLANGE "A" 6000PSI, OUTLET	WEIGHT KG
066	1 1/2"	1"	55
090	2"	1"	57
130	2 1/2"	1"	111
180	2 1/2"	1 1/4"	113
250	3 1/2"	1 1/4"	226

SIZE	B1	B2	B3	B4	B5	B6	B7 h9	B8	B9	B10	B11	B12
066	210	116	160	235	130	180	10	116	58	52	182.5	—
090	210	116	160	235	130	180	10	116	58	52	182.5	157.5
130	260	140	200	265	224	224	14	140	70	52	182.5	—
180	260	140	200	265	224	224	14	140	70	52	182.5	—
250	325	180	250	330	280	280	18	175	87.5	52	182.5	—

SIZE	D1 h8	D2 k6	D3	D4	D5	D6 Light Execution	D7	DEEP	D8	D9	DEEP	D10	D11	DEEP	D12	D13 SAE 475	D14
066	125	38	M12	18	M8	M22x1.5	M10	24	38	M12	24	25	M12	21	—	7/8-14UNF	64
090	125	38	M12	18	M8	M22x1.5	M10	20	50	M12	24	25	M12	21	—	7/8-14UNF	64
130	160	50	M16	22	M10	M26x1.5	M12	20	62	M12	20	25	M12	20	M20	1 1/16-12UNF	88
180	160	50	M16	22	M10	M26x1.5	M12	20	62	M12	20	32	M14	20	M20	1 1/16-12UNF	88
250	200	65	M20	26	M12	M33x2	M16	32	90	M16	32	32	M14	24	M24	1 5/16-12UNF	88

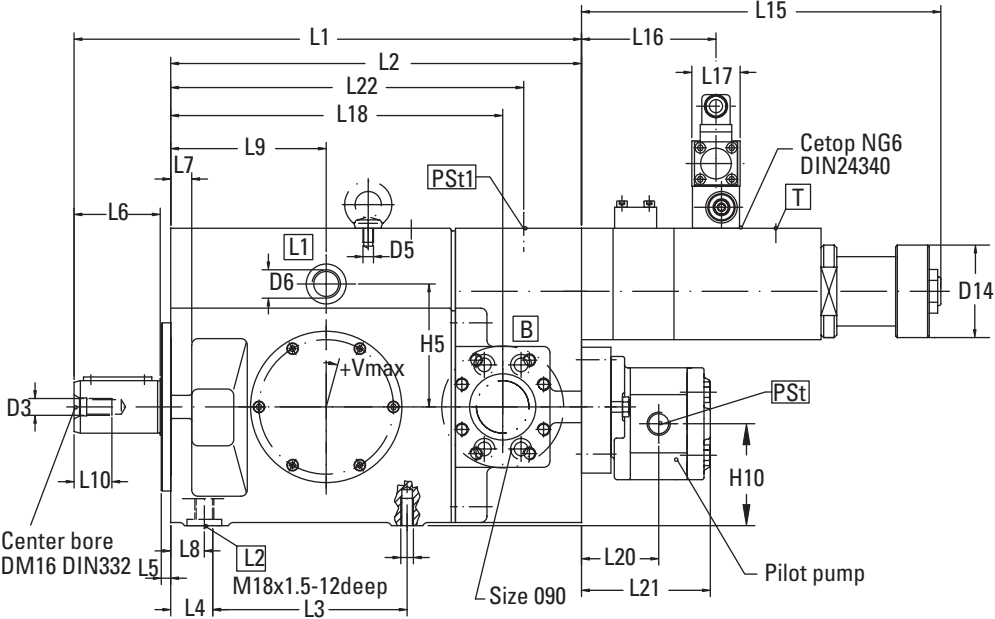
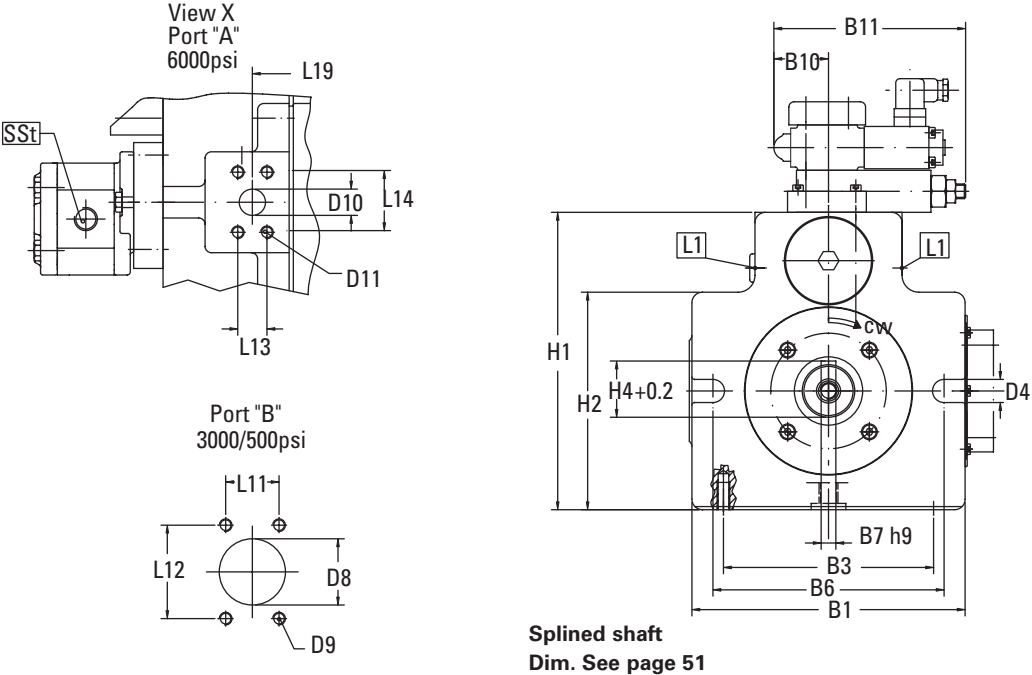

SIZE	H1	H2	H3	H4 +0.2	H5	H6	H7	H8	H9	H10	H11
066	227	162	90	41	93	53	88	137	127	97	113
090	227	162	90	41	93	53	88	137	127	97	113
130	283	207	113	53.5	117	64	110	170	127	97	131
180	283	207	113	53.5	117	64	110	170	127	97	131
250	354	260	140	69	146	77	138	214	127	124	167

SIZE	L1	L2	L3	L4	L5	L6	L7	L8	L9	L10	L11	L12	L13	L14	L15	L16	L17	L18	L19	L20	L21	L22
066	342	274	150	35	8	58	16	26	120	28	35.7	69.8	27.8	57.2	267	104	46	245.6	245.6	73.5	122.6	230.6
090	342	274	150	35	8	58	16	26	120	28	42.88	77.77	27.8	57.2	267	104	46	245.6	245.6	73.5	122.6	230.6
130	483	391	185	40	9	82	20	32	148	36	50.8	89	27.8	57.2	342	128	46	316	306	73.5	122.6	336
180	483	391	185	40	9	82	20	32	148	36	50.8	89	31.8	66.7	342	128	46	316	306	73.5	122.6	336
250	622	505	230	50	10	105	25	41	187	42	69.8	120.7	31.8	66.7	387	150	46	403	403	73.5	122.6	437

# Pump Dimensions - ATUS-PVXS 066 - 250

## Side ports - Proportional Valve Displacement Control SPC03A.....E...

1. Proportional valve
2. Pressure limiter
3. Filter

Dimensions in mm

- T G1/2"
- Pst G1/2"
- Mst G1/4"
- L1 Two drain ports, one supplied plugged
- L2 M18x1, 5x12-deep supplementary drain, or bleed plug. Must be drained in addition to if the pump is installed with the shaft input end pointing upwards.
- MA G1/4"x12.5-deep gauge port supplied plugged

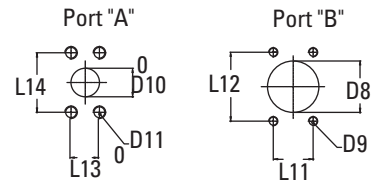
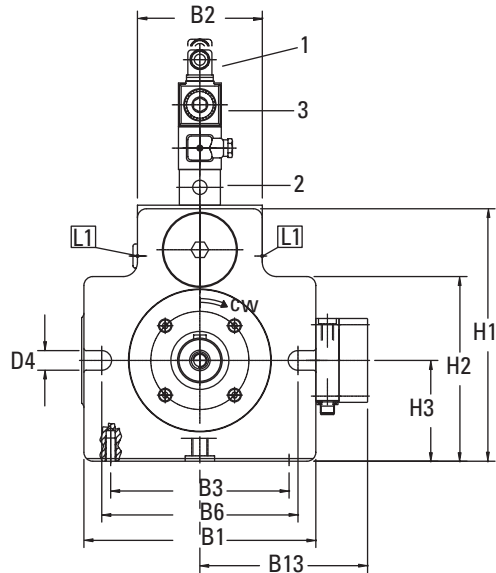

DIRECTION OF ROTATION	CONTROL	INPUT	OUTPUT
Right Hand Rotation	To + Vmax	B	A
	To - Vmax	A	B
Left Hand Rotation	To + Vmax	A	B
	To - Vmax	B	A

SIZE	SAE-FLANGE "B" 3000(500)PSI, INLET	SAE-FLANGE "A" 6000PSI, OUTLET	WEIGHT KG
066	1 1/2"	1"	55
090	2"	1"	57
130	2 1/2"	1"	111
180	2 1/2"	1 1/4"	113
250	3 1/2"	1 1/4"	226

SIZE	B1	B2	B3	B4	B5	B6	B7 h9	B8	B12	B13
066	210	116	160	235	130	180	10	116	—	165
090	210	116	160	235	130	180	10	116	157.5	165
130	260	140	200	265	224	224	14	140	—	190
180	260	140	200	265	224	224	14	140	—	190
250	325	175	250	330	280	280	18	175	—	221

SIZE	D1 h8	D2 k6	D3	D4	D5	D6 Light Execution	D7	DEEP	D8	D9	DEEP	D10	D11	DEEP	D12
066	125	38	M12	—	7/8-UNF	M22x1.5	M10	20	38	M12	24	25	M12	21	—
090	125	38	M12	18	7/8-UNF	M22x1.5	M10	20	50	M12	24	25	M12	21	—
130	160	50	M16	22	1 1/16-UNF	M26x1.5	M12	20	62	M12	20	25	M12	20	M20
180	160	50	M16	22	1 1/16-UNF	M26x1.5	M12	20	62	M12	20	32	M14	20	M20
250	200	65	M20	26	1 1/16-UNF	M33x2	M16	32	90	M16	32	32	M14	24	M24



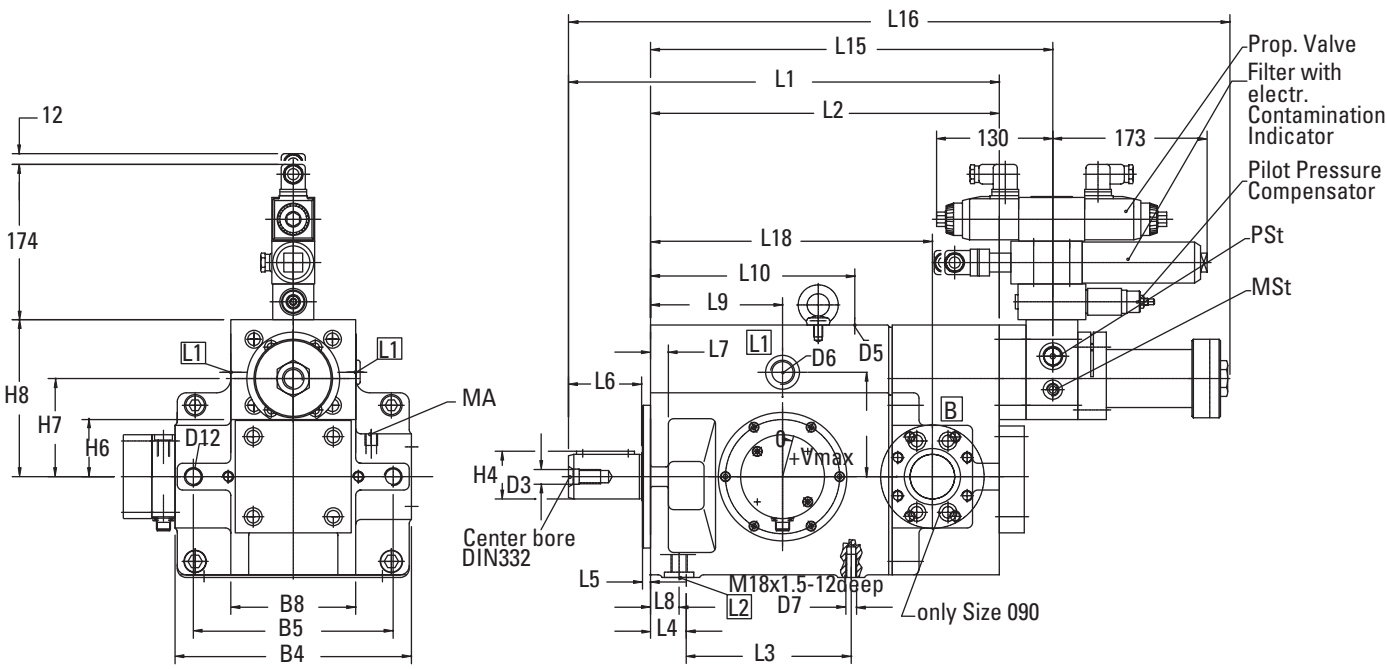

Splined shaft  
Dim. See page 51

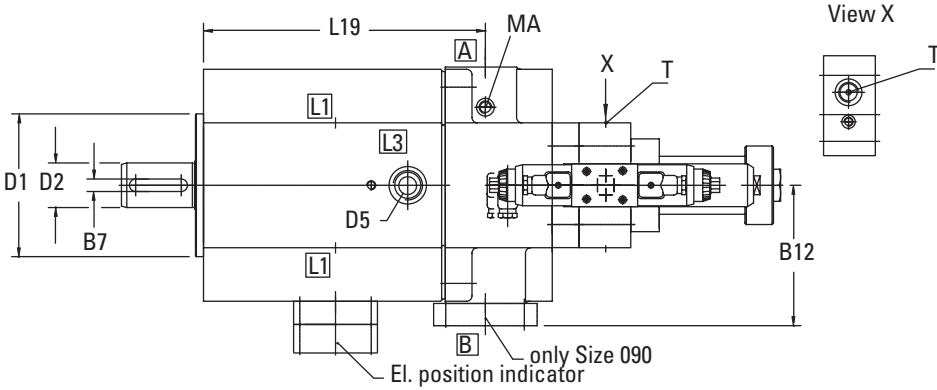

SIZE	H1	H2	H3	H4 +0.2	H5	H6	H7	H8
066	227	162	90	41	93	53	88	139
090	227	162	90	41	93	53	88	139
130	283	207	113	53.5	117	64	110	176
180	283	207	113	53.5	117	64	110	176
250	354	260	140	69	146	77	138	220

SIZE	L1	L2	L3	L4	L5	L6	L7	L8	L9	L10	L11	L12	L13	L14	L15	L16	L18	L19	L20	L21
066	342	274	150	35	8	58	16	26	120	185	35.7	69.8	27.8	57.2	328	576	245.6	245.6	68	58
090	342	274	150	35	8	58	16	26	120	185	42.88	77.77	27.8	57.2	328	576	245.6	245.6	68	58
130	483	391	185	40	9	82	20	32	148	229	50.8	89	27.8	57.2	451	738	316	306	78	68
180	483	391	185	40	9	82	20	32	148	229	50.8	89	31.8	66.7	451	738	316	306	78	68
250	622	505	230	50	10	105	25	41	187	281	69.8	120.7	31.8	66.7	579	931	403	403	90	80

# Pump Dimensions - ATUS-PVXSThru-Drive

Mounting, Thru-Drive Options  
SAE "A" and SAE "B"

**ATUS-PVX 066 / 090**  
SAE "A"

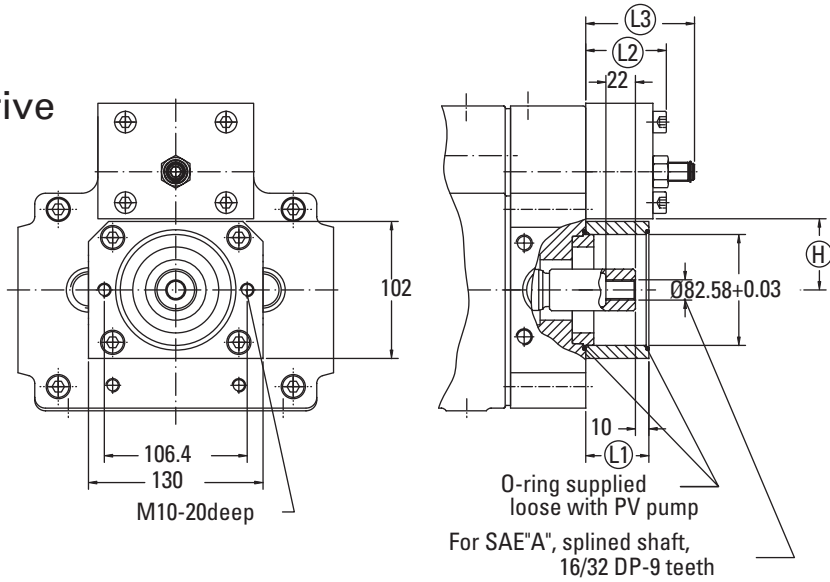

**ATUS-PVX 130 / 180 / 250**  
SAE "A"

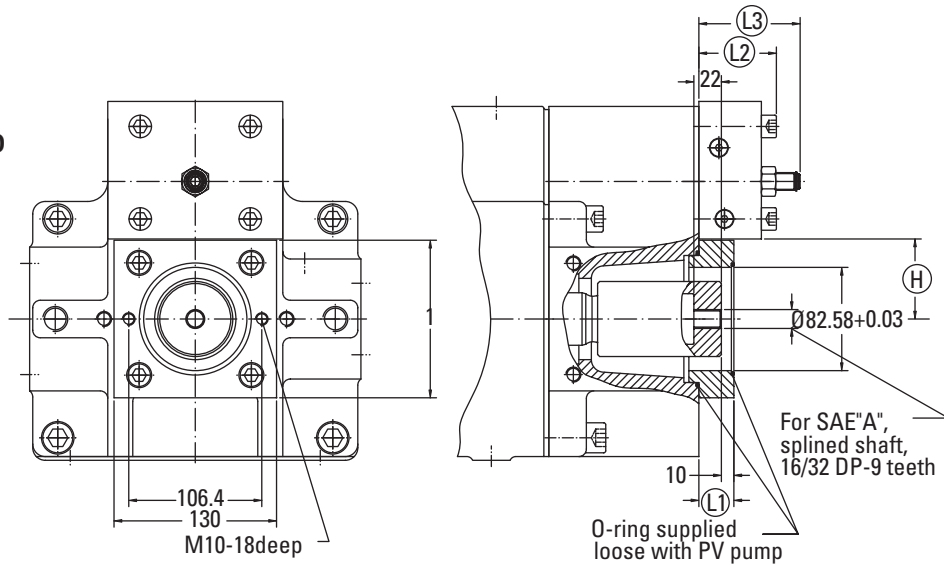

**ATUSPVX 130 / 180 / 250**  
SAE "B"

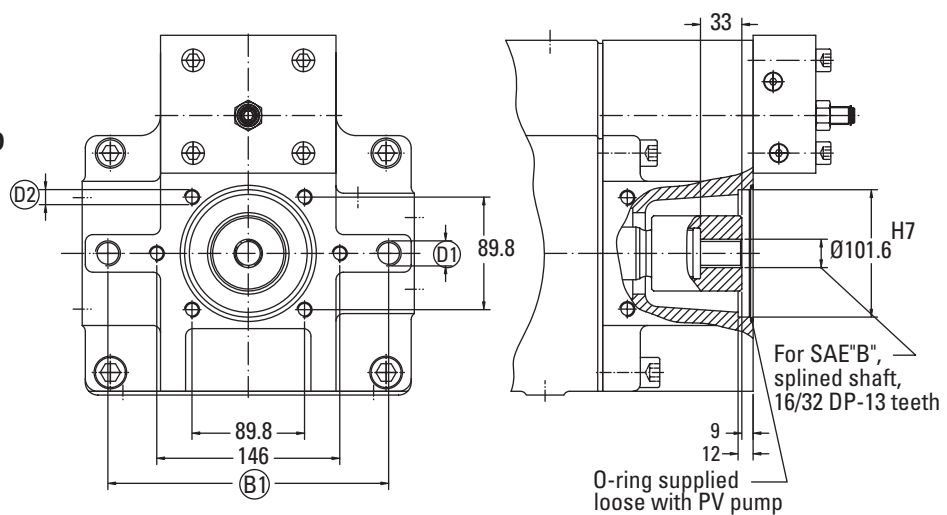

SIZE	THROUGH SHAFT	B1	D1	D2	L1	L2	L3	H
066/090	SAE "A"	—	—	—	47	60	81	53
130/180	SAE "A"	224	M20-30 deep	M12-20 deep	28	62	81	64
	SAE "B"	—	—	—	—	62	81	64
250	SAE "A"	280	M24-38 deep	M12-24 deep	28	56	91	77
	SAE "B"	—	—	—	—	56	91	77

# Pump Dimensions - Splined Shafts

For Variable Displacement  
Pumps (ATUS-PVXS) Only

## Size 066 / 090

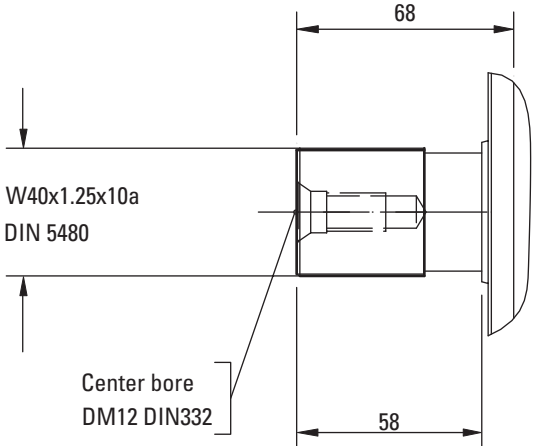

## Size 130 / 180

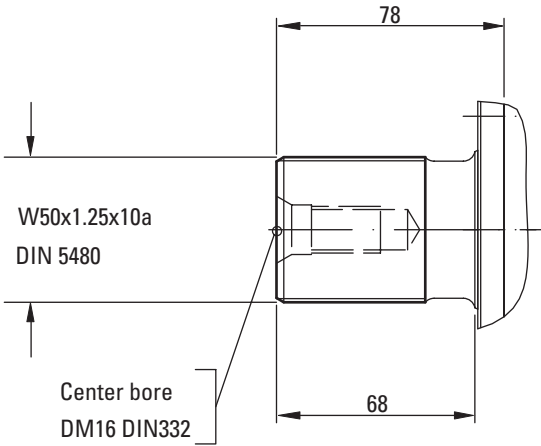

## Size 250

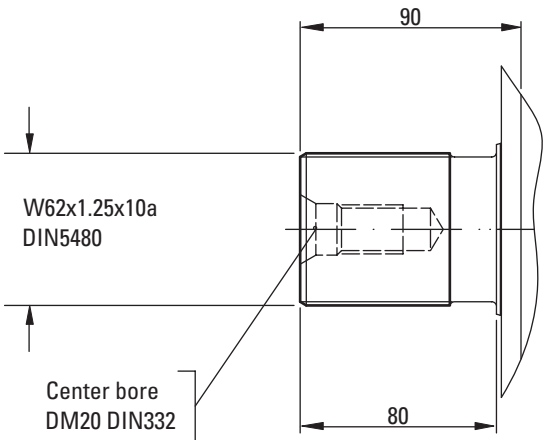

# Pump Dimensions - ATUS-PVXS SAE 4- Bolt Mounting Pads

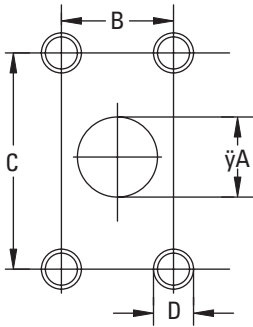

DIM.	CODE 61 SERIES				CODE 62 SERIES	
	1 1/2"	2"	2 1/2"	3 1/2"	1"	1 1/4"
A	38	50	62	90	25	32 max
B	35,7	42,9	50,8	69,8	27,8	31,8
C	69,8	77,8	89	120,7	57,2	66,7
D	M12x20	M12x20	M12x20	M16x26	M12x18	M14x24

ATUS-PFX / PVX 066	Inlet	•				
	Outlet				•	
ATUS-PFX / PVX 090	Inlet	•				
	Outlet				•	
ATUS-PFX / PVX 130	Inlet		•			
	Outlet				•	
ATUS-PFX / PVX 180	Inlet		•			
	Outlet					•
ATUS-PFX / PVX 250	Inlet			•		
	Outlet					•

## Thru-drive Shaft Output Torque

Pump Size	MAX. OUTPUT TORQUE, NM (LB.FT)		
	Keyed Shaft Increasing Load	Keyed Shaft Increasing Load	Splined Shaft
066	520 (383)	260 (190)	660 (485)
090	520 (383)	260 (190)	660 (485)
130	720 (530)	360 (265)	900 (665)
180	720 (530)	360 (265)	900 (665)
250	1400 (1032)	1400 (1032)	2500 (1843)

## Installation Drain piping

### Shaft up

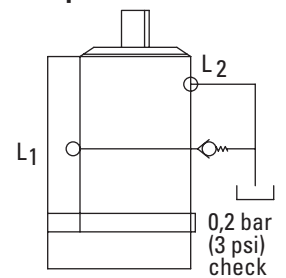

### Shaft down

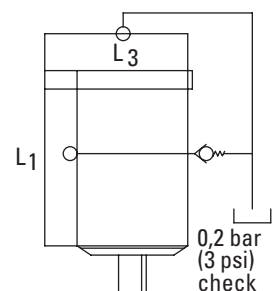

## Application Data - Fluid Recommendations

### Case Flushing Requirements

A check valve must not be used in the drain pipe. The drain pipe must interminate below the oil level in the reservoir.

For all other conditions with low pressure <20 bar (<300 psi) and low flow (<10% of  $Q_{max}$ ) case flushing is required.

For operation with special fluids HFB and HFC, case flushing is recommended.

### Flushing Flow

Flushing flow via the pump case should be >1% of maximum pump flow. Maximum flushing flow depends on case pressure.

### Notes:

- All listed ratings are based on the use of a good quality fluid.
- Alternative fluids have a reduced tolerance for contamination over petroleum base fluids. Good filtration is therefore critical.
- The pumps will provide exceptional life when used with a good quality clean fluid at the pump ratings specified for that fluid.

### Fluids

Pumps in the catalog are primarily designed to operate with conventional petroleum based hydraulic oil. Alternative fluids and restrictions:

- Fluid maintenance is critical to the durability of all hydraulic components, and particularly so with hydraulic pumps. This becomes even more of a factor when alternative fluids are used. All types of alternative fluids require extensive maintenance in order to maintain proper levels of water content, acidity, viscosity and contamination.

### Fluid Cleanliness

These pumps are rated for anti-wear petroleum fluids with a contamination level of 18/15/13 per ISO 4406. Operation in fluids with levels more contamination than this is not recommended and may reduce the life of the pump components. Fluids other than petroleum, severe service cycles, or temperature extremes are cause for adjustment of these codes. Please contact your ATUS representative for special duty cycle recommendations.

ATUS pumps, as well as any variable displacement piston pumps, will operate with apparent satisfaction in fluids up to the rating specified here. Experience has shown, however, that pump and hydraulic system life is not optimized with high fluid contamination levels (high ISO cleanliness codes).

Proper fluid condition is essential for long and satisfactory life of hydraulic components and systems. Hydraulic fluid must have the

correct balance of cleanliness, materials, and additives for protection against wear of inclusion of air.

Essential information on the correct methods for treating hydraulic fluid is included in ATUS publication 561- "ATUS Guide to Systemic Contamination Control"- available from your local ATUS distributor.

In this publication, filtration and cleanliness levels for extending the life of axial piston pumps and other system components are listed. Included is an excellent discussion of the selection of products needed to control fluid condition.

### Ordering Procedure

When ordering please specify full model designation of items required; see "Model Codes" section of this catalog.

Note the following:

- Designation of variable displacement pumps must include the supplementary designation of the required control.

### FLUIDS

Type	Classification	Max. Pressure Bar	Max. Speed rpm	Recommended Seal Material	Max Operating Temperature °C	Bearing Life
Oil in Water Emulsion	HFAE	Not Rated				0
Water in Oil Emulsion	HFB	250	1800	Fluorocarbon	49	50%
Water Glycol	HFC	250	1800	Fluorocarbon	49	25%
Phosphate Ester	HFDR	350/420	1800	Fluorocarbon	66	100%
Polyol Ester	HFDU	350/420	1800	Fluorocarbon	66	100%



Notes

