

## Variable vane pumps, pilot operated

### Type PV7

Sizes 14 to 150  
Series1X  
Maximum operating pressure 160 bar  
Maximum flow 270 l/min

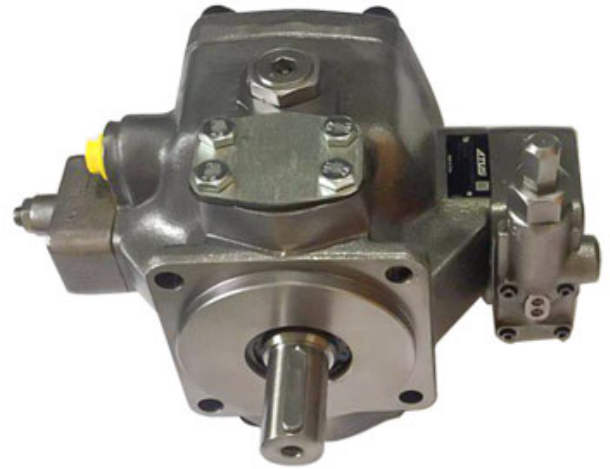

### Table of contents

Contents	Page
Contents	
Features	1
Ordering code	2
Standard types, symbols	3
Function, section	4 and 5
Technical data	6
Characteristic curves	7 to 12
Unit dimensions, single pump with controller	13
Dynamic characteristics of the pressure control	14
Controller programme (symbols, characteristic curves, unit dimensions)	15 to 19
Lock	20
Notes on the engineering of multiple pumps	20
Combination options, ordering code of multiple pumps	21
Unit dimensions of pump combinations	22 to 27
SAE connection flanges	28
Engineering notes	28 and 29
Commissioning notes	29
Installation notes	30

### Features

- Variable displacement
- Low operating noise
- Long service life due to hydrodynamically lubricated plain bearings
- Control of pressure and flow possible
- Low hysteresis
- Very short on and off-stroke times
- Mounting and connection dimensions to
  - VDMA 24560 part 1
  - ISO 3019/2
- Suitable for HETG and HEES media
- Standard single pumps of series PV7 can be flexibly combined to form multiple pumps
- PV7 pumps can additionally be combined with internal and external gear pumps, axial piston and radial piston pumps

## Ordering code

Frame sizes and sizes	Pipe connection	Zero stroke pressure range
FS 10 - size 14 cm <sup>3</sup> = 10-14	= 01	16 = up to 160 bar
FS 10 - size 20 cm <sup>3</sup> = 10-20	= 01	10 = up to 100 bar
FS 16 - size 20 cm <sup>3</sup> = 16-20	= 01	16 = up to 160 bar
FS 16 - size 30 cm <sup>3</sup> = 16-30	= 01	08 = up to 80 bar
FS 25 - size 30 cm <sup>3</sup> = 25-30	= 01	16 = up to 160 bar
FS 25 - size 45 cm <sup>3</sup> = 25-45	= 01	08 = up to 80 bar
FS 40 - size 45 cm <sup>3</sup> = 40-45	= 37	16 = up to 160 bar
FS 40 - size 71 cm <sup>3</sup> = 40-71	= 37	08 = up to 80 bar
FS 63 - size 71 cm <sup>3</sup> = 63-71	= 07	16 = up to 160 bar
FS 63 - size 94 cm <sup>3</sup> = 63-94	= 07	08 = up to 80 bar
FS 100 - size 118 cm <sup>3</sup> = 100-118	= 07	16 = up to 160 bar
FS 100 - size 150 cm <sup>3</sup> = 100-150	= 07	08 = up to 80 bar

PV7-1X / R E M -

### Component series

Component series 10 to 19  
(10 to 19: unchanged installation  
and connection dimensions)

= 1X

### Direction of rotation

Clockwise

= R

### Shaft end

Cylindrical drive shaft with output

= E

### Line port

Standard version

#### FS 10, 16, 25:

Suction, pressure port: Pipe thread

= 01

#### FS 40:

Suction port: SAE flange connection,  
pressure port: Pipe thread

= 37

#### FS 63, 100

Suction, pressure port: SAE flange connection

= 07

### Directional valve <sup>1)</sup>

WG = Normally closed

WH = Normally open

### Controller option

0 = Standard

3 = Lockable

5 = With K plate

6 = With Q plate

7 = Lockable with K plate

8 = Lockable with O plate

### Type of controller

C = Pressure controller

D = Pressure controller for hydraulic  
pressure remote control

N = Flow controller

W = Pressure controller with electrical  
2-stage pressure adjustment element

### Seal material

M = NBR seals

Order examples: PV7-1X/16-20RE01MC5-16

PV7-1X/40-45RE37MD0-16

### Pump with custom setting:

Please state the required setting in clear text on the order (e.g.  $q_{Vmax} = 20$  l/min;  $p_{zero\ stroke} = 70$  bar). The pump will then be set to the desired values and the operating noise optimised accordingly.

Without indication in clear text, the flow and the zero stroke pressure will be set to the relevant maximum values and the operating noise optimised to these maximum values.

<sup>1)</sup> Only for C5, D5 and W controllers (optional)

## Symbols

---

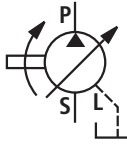

Single pump

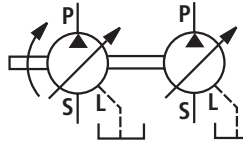

Double pump

## Function, section

### Design

Hydraulic pumps of type PV7 are vane pumps with variable displacement.

They basically consist of housing (1), rotor (2), vanes (3), stator ring (4), pressure controller (5) and adjustment screw (6).

The circular stator ring (4) is retained by the small reciprocating control piston (10) and the large reciprocating control piston (11). The third supporting point of the ring is height adjustment screw (7).

The driven rotor (2) rotates within stator ring (4). The vanes guided within the rotor are pressed against stator ring (4) by centrifugal force.

### Adjustment

As pressure builds up in the system, the rear side of the small control piston (10) is always pressurised to system pressure via a channel.

In the displacement position, the rear side of the large control piston (11) is also pressurised to system pressure via a bore in control spool (14). Control piston (11) with the larger area holds stator ring (4) in its eccentric position.

The pump displaces fluid at a pressure below the zero stroke pressure set on pressure controller (5).

Control spool (14) is held by spring (13) in a certain position.

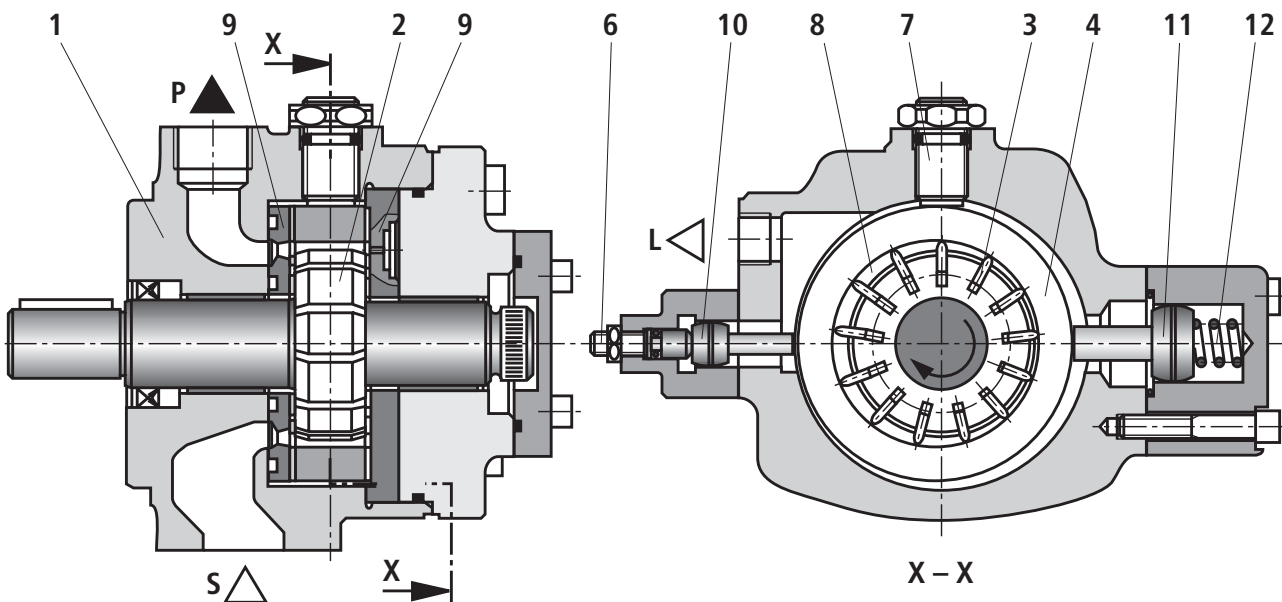

### Suction and displacement process

The cells (8) required for transporting the fluid are formed by vanes (3), rotor (2), stator ring (4) and control plates (9).

To ensure the pump function during commissioning, stator ring (4) is held by spring (12) behind the large control piston (11) in its eccentric position (displacer position).

While rotor (2) is rotating, the volume of cells (8) increases and fill with fluid via suction channel (S). When the largest cell volume has been reached, cells (8) are disconnected from the suction side. As rotor (2) continues to rotate, they are connected to the pressure side, become smaller and displace fluid via pressure channel (P) into the system.

## Function

### Off-stroke control

When force  $F_P$ , which results from the product of pressure  $\times$  area, exceeds counterforce  $F_S$  of the spring, control spool (14) is pressed against spring (13). In this way, the chamber behind large control piston (11) is connected to the tank and thus unloaded.

The small control piston (10), which is constantly under system pressure, shifts stator ring (4) almost to the central position. The pump maintains the current pressure, the flow is reduced to zero and only leakages are compensated for.

Power losses and heating of the fluid are kept at a low level. The  $q_V$ - $p$  characteristic curve runs vertically and shifts in parallel as higher pressures are set.

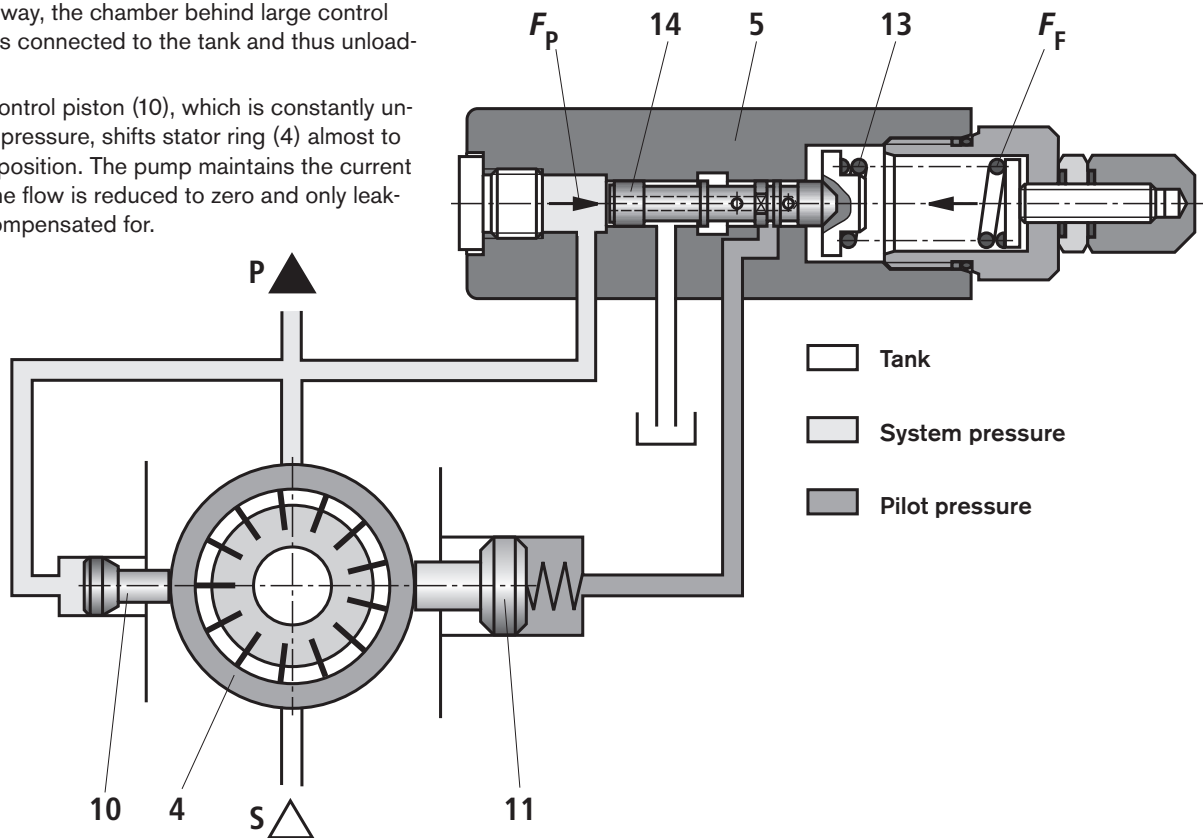

### On-stroke control

When the pressure in the system falls below the set zero stroke pressure, spring (13) pushes control spool (14) back to its original position.

The large control piston (11) is again pressurised and shifts stator ring (4) to an eccentric position. The pump starts to displace again.

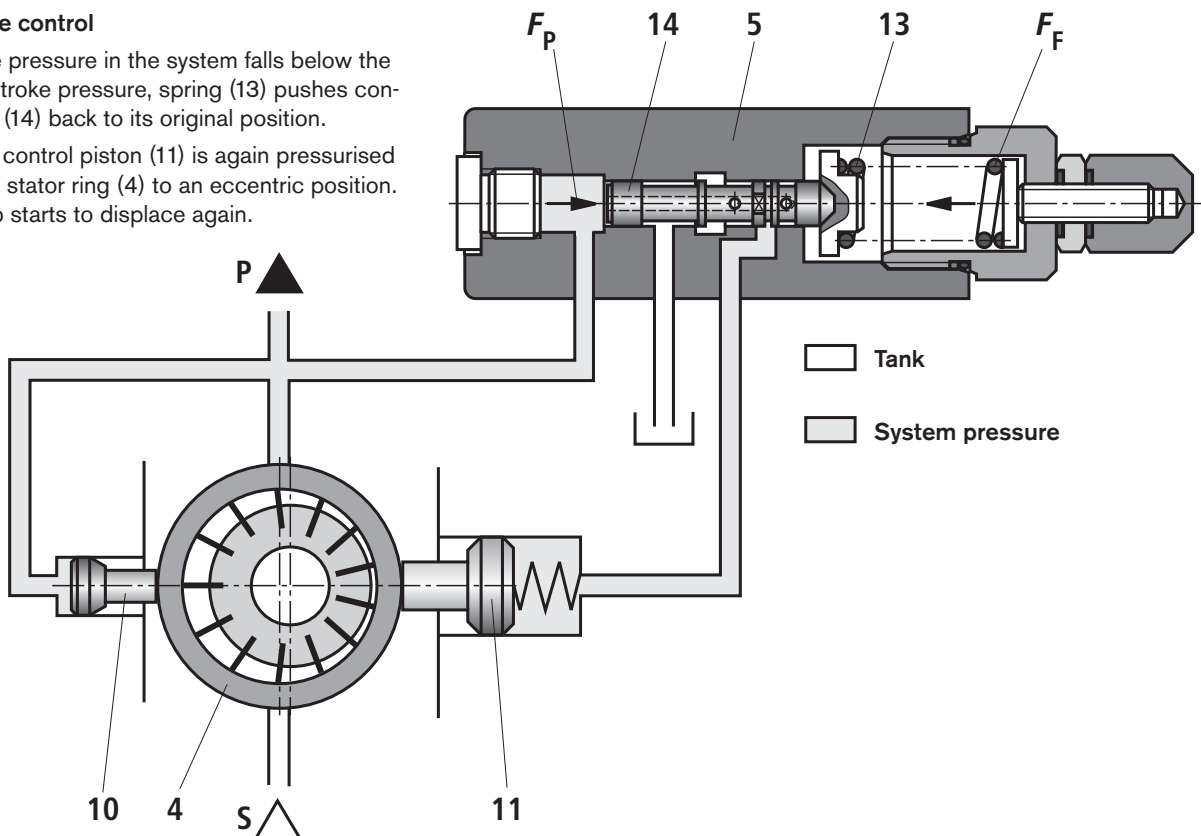

## Technical data (for applications outside these parameters, please consult us!)

Design	Pilot operated vane pump, variable													
Type	PV7													
Type of mounting	4-hole flange (to VMDA 24560 part 1 and ISO 3019/2)													
Pipe connections	Pipe thread or SAE flange connection (depending on frame size)													
Installation orientation	Optional, preferably horizontal (see pages 28 and 29)													
Shaft loading	Radial and axial forces <b>cannot</b> be transmitted													
Direction of rotation	Clockwise (viewed to shaft end)													
Drive speed	$n$	$\text{min}^{-1}$	900 to 1800											
Frame size	FS		10		16		25		40		63		100	
Size	$V_g$	$\text{cm}^3$	14	20	20	30	30	45	45	71	71	94	118	150
Input power <sup>1)</sup>	$P_{\max}$	kW	6.3	5.8	8.5	6.8	13.7	10.2	20.5	16.5	33	20.9	51.5	33
Permissible input torque	$T_{\max}$	Nm	90		140		180		280		440		680	
Max. flow <sup>2)</sup>	$q_V$	l/min	21	29	29	43.5	43.5	66	66	104	108	136	171	218
Leakage flow at zero stroke (at operating pressure output = $p_{\max}$ )	$q_{VL}$	l/min	2.7	1.9	4	2.5	5.3	3.2	6.5	4	8	5.3	11	7.3
Operating pressure, absolute														
– Inlet	$p_{\min-\max}$	bar	0.8 to 2.5											
– Outlet <sup>3)</sup>	$p_{\max}$	bar	160	100	160	80	160	80	160	80	160	80	160	80
– Leakage outlet	$p_{\max}$	bar	2											
Hydraulic fluid for operation at up to 160 bar (nominal pressure)	HLP mineral oil to DIN 51524 part 2													
<b>Special hydraulic fluids</b> <sup>4)</sup>														
– Up to operating pressure $p_{\max} = 100$ bar	HET and HEES hydraulic fluids to VDMA 24 568													
– Up to operating pressure $p_{\max} = 80$ bar	HLP mineral oil to DIN 51524 part 2 (100 $\text{mm}^2/\text{s}$ or higher) HL mineral oil to DIN 51524 part 1													
Hydraulic fluid temperature range	$\vartheta$	$^{\circ}\text{C}$	–10 to +70; observe permissible viscosity range!											
Viscosity range	$\nu$	$\text{mm}^2/\text{s}$	16 to 1600 at operating temperature max. 800 when starting up in displacement mode max. 200 when starting up in zero stroke mode											
Max. permissible degree of contamination of the hydraulic fluid - cleanliness class to ISO 4406 (c)	Class 20/18/15 <sup>5)</sup>													
Weight (with pressure controller)	$m$	kg	12.5		17		21		30		37		56	
Change of flow (with one turn of the adjustment screw and at $n = 1450 \text{ min}^{-1}$ )	$q_V$	l/min	10		14		18		25		34		46	

<sup>1)</sup> Measured at  $n = 1450 \text{ min}^{-1}$ ;  $p = p_{\max}$ ;  $\nu = 41 \text{ mm}^2/\text{s}$

<sup>2)</sup> Due to manufacturing tolerances, the specified flow values can be exceeded by approx. 6 % (measured at  $n = 1450 \text{ min}^{-1}$ ;  $p = 10 \text{ bar}$ ;  $\nu = 41 \text{ mm}^2/\text{s}$ ).

<sup>3)</sup> The settable minimum pressure is approx. 20 bar; the factory setting is 30 bar as a standard.

<sup>4)</sup> Further special hydraulic fluids (e.g. for plant in the food processing industry or flame-retardant fluids) on enquiry

<sup>5)</sup> The cleanliness classes specified for components must be

adhered to in hydraulic systems. Effective filtration prevents malfunction and, at the same time, prolongs the service life of components.

For the selection of filters, see data sheets RE 50070, RE 50076, RE 50081, RE 50086 and RE 50088.

**Characteristic curves** (measured at  $n = 1450 \text{ min}^{-1}$ ,  $v = 41 \text{ mm}^2/\text{s}$  and  $\vartheta = 50 \text{ }^\circ\text{C}$ )

PV7/10-14

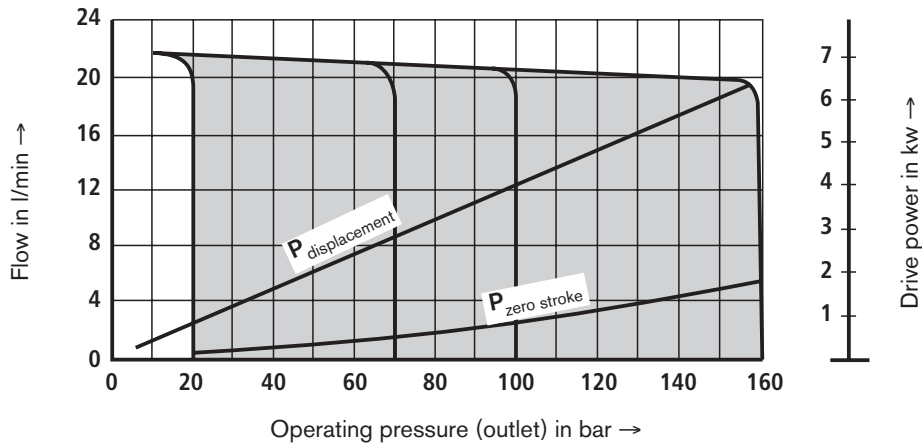

PV7/10-20

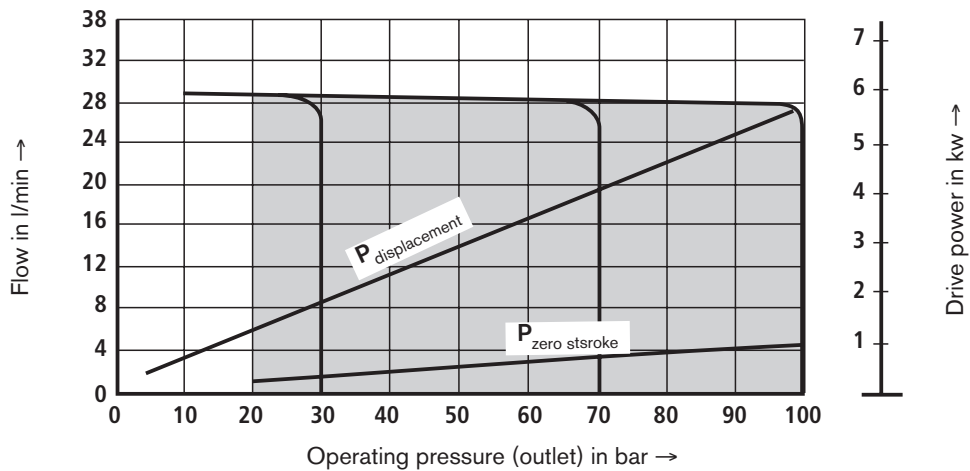

**Sound pressure level** measured in the anechoic chamber according to DIN 45635 part 26. Distance between microphone – pump = 1 m.

**Please take this into account for the order!**

The pump setting is selected so that the most favourable sound pressure level is obtained at the relevant highest zero stroke

stroke pressure. It is therefore essential to specify the required zero stroke pressure on the order, unless it corresponds to the nominal pressure.

Observe engineering notes on page 28 and 30 .

PV7/10-14

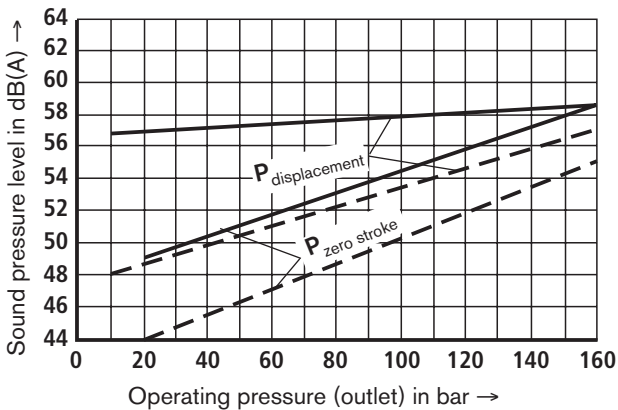

PV7/10-20

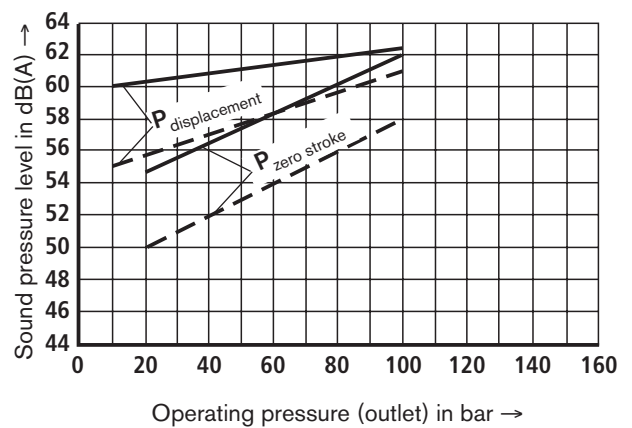

Drive speed: ———  $n = 1450 \text{ min}^{-1}$

- - - - -  $n = 1000 \text{ min}^{-1}$

**Characteristic curves** (measured at  $n = 1450 \text{ min}^{-1}$ ,  $\nu = 41 \text{ mm}^2/\text{s}$  and  $\vartheta = 50^\circ\text{C}$ )

PV7/16-20

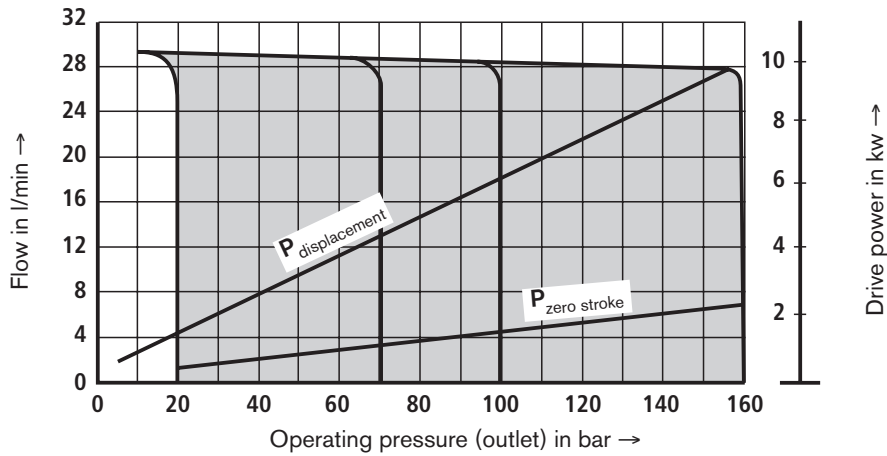

PV7/16-30

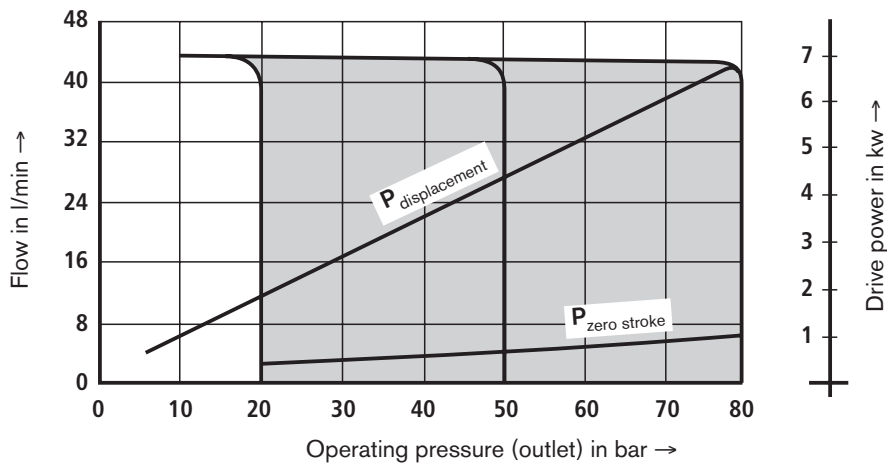

**Sound pressure level** measured in the anechoic chamber according to DIN 45635 part 26. Distance between microphone – pump = 1 m.

**Please take this into account for the order!**

The pump setting is selected so that the most favourable sound pressure level is obtained at the relevant highest zero

stroke pressure. It is therefore essential to specify the required zero stroke pressure on the order, unless it corresponds to the nominal pressure.

Observe the engineering notes on pages 28 and 30.

PV7/16-20

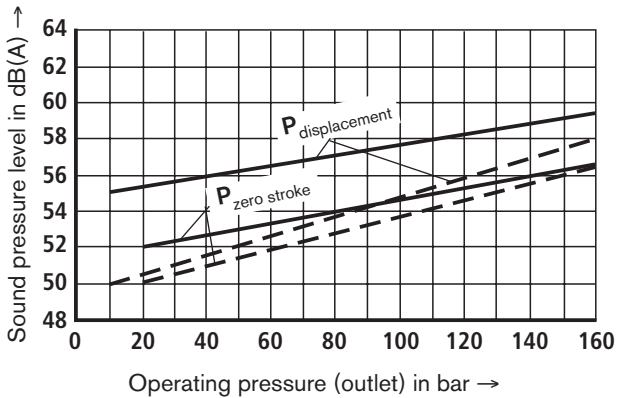

PV7/16-30

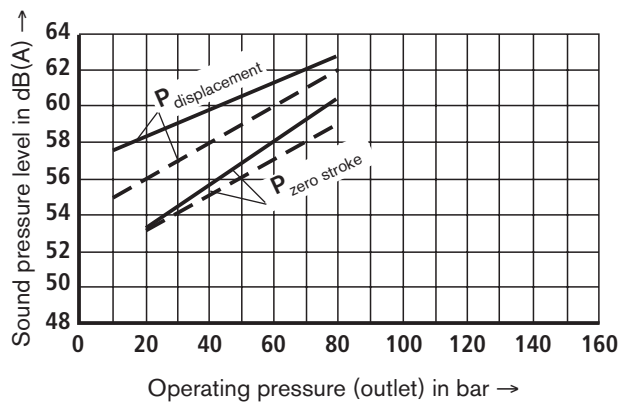

Drive speed: ———  $n = 1450 \text{ min}^{-1}$   
 - - - -  $n = 1000 \text{ min}^{-1}$



**Characteristic curves** (measured at  $n = 1450 \text{ min}^{-1}$ ,  $v = 41 \text{ mm}^2/\text{s}$  and  $\vartheta = 50^\circ\text{C}$ )

PV7/25-30

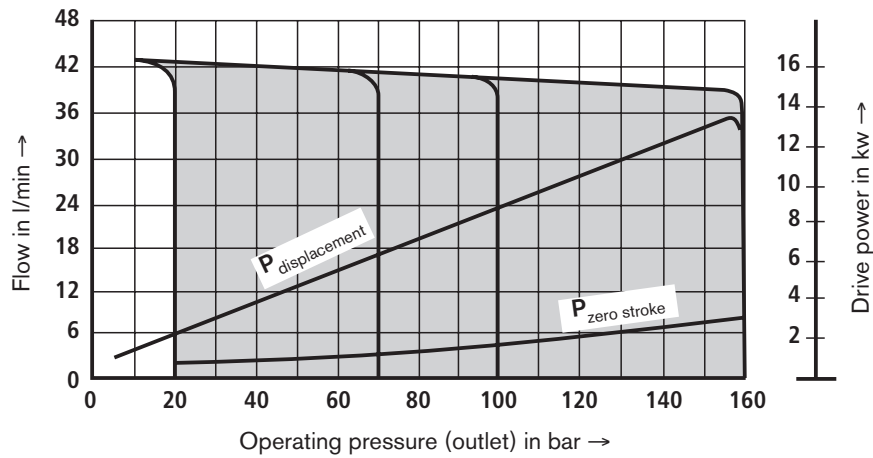

PV7/25-45

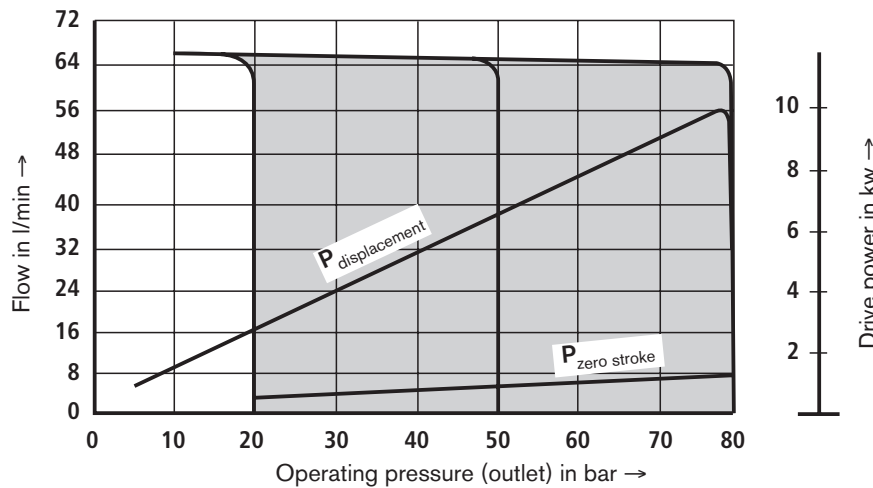

**Sound pressure level** measured in the anechoic chamber according to DIN 45635 part 26. Distance between microphone – pump = 1 m.

**Please take this into account for the order!**

The pump setting is selected so that the most favourable sound pressure level is obtained at the relevant highest zero stroke

stroke pressure. It is therefore essential to specify the required zero stroke pressure on the order, unless it corresponds to the nominal pressure.

Observe the engineering notes on pages 28 and 30.

PV7/25-30

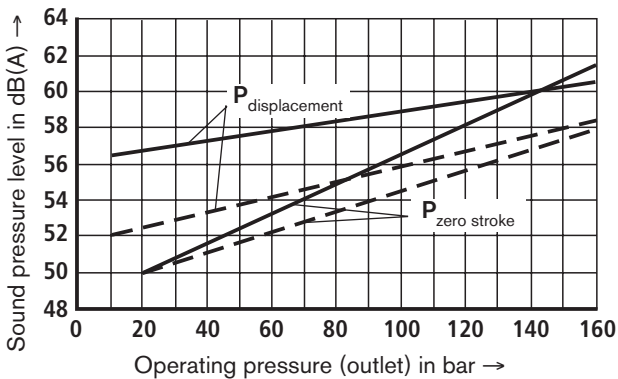

PV7/25-45

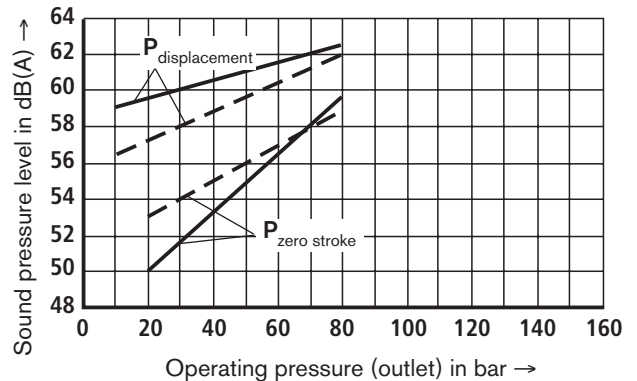

Drive speed: ———  $n = 1450 \text{ min}^{-1}$

- - - -  $n = 1000 \text{ min}^{-1}$

**Characteristic curves** (measured at  $n = 1450 \text{ min}^{-1}$ ,  $v = 41 \text{ mm}^2/\text{s}$  and  $\vartheta = 50^\circ\text{C}$ )

PV7/40-45

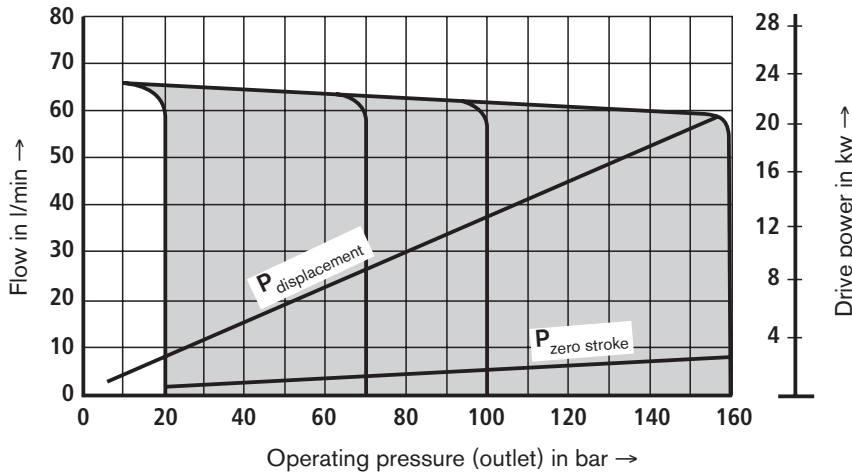

PV7/40-71

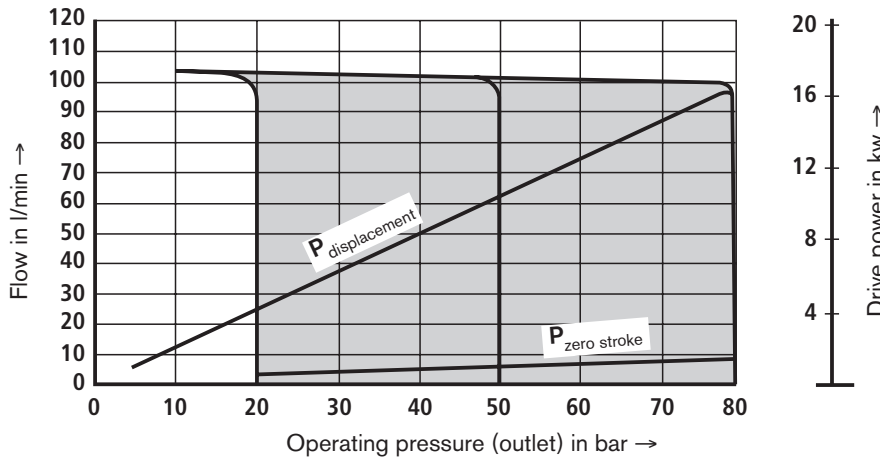

**Sound pressure level** measured in the anechoic chamber according to DIN 45635 part 26. Distance between microphone – pump = 1 m.

**Please take this into account for the order!**

The pump setting is selected so that the most favourable sound pressure level is obtained at the relevant highest zero

stroke pressure. It is therefore essential to specify the required zero stroke pressure on the order, unless it corresponds to the nominal pressure.

Observe the engineering notes on pages 28 and 30.

PV7/40-45

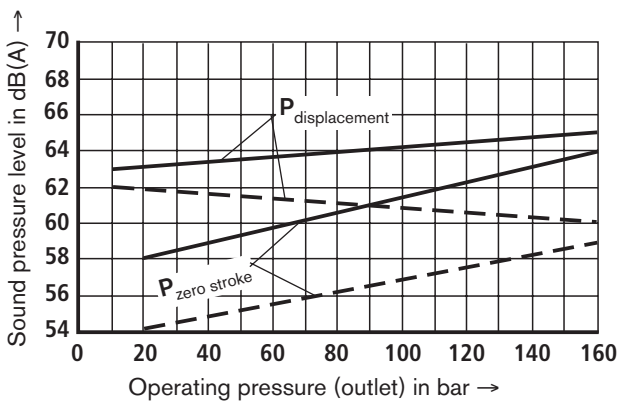

PV7/40-71

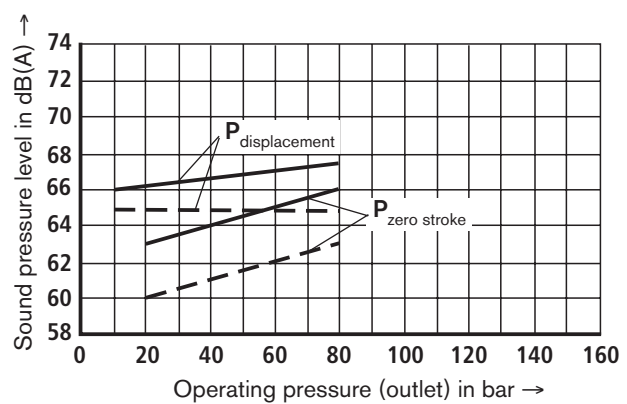

Drive speed: ———  $n = 1450 \text{ min}^{-1}$

- - - - -  $n = 1000 \text{ min}^{-1}$

**Characteristic curves** (measured at  $n = 1450 \text{ min}^{-1}$ ,  $v = 41 \text{ mm}^2/\text{s}$  and  $\vartheta = 50^\circ\text{C}$ )

PV7/63-71

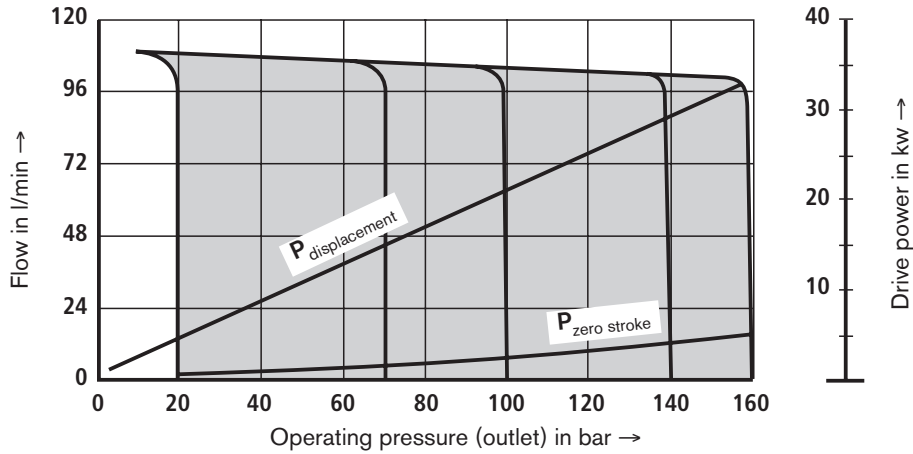

PV7/63-94

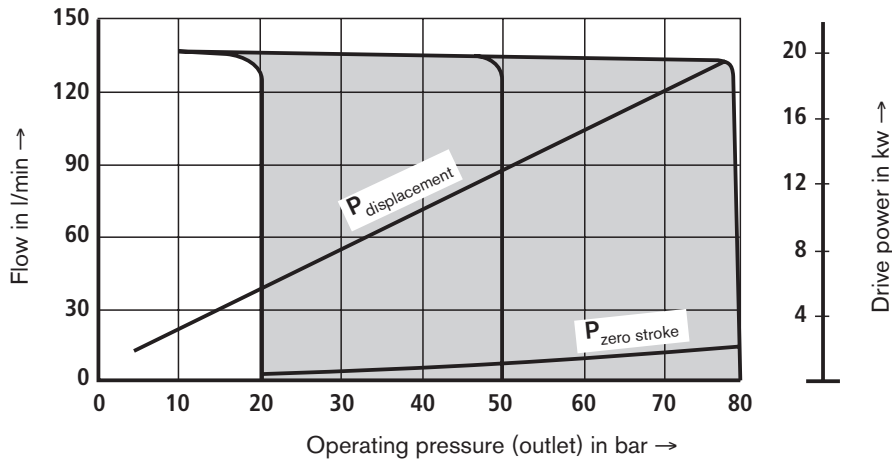

**Sound pressure level** measured in the anechoic chamber according to DIN 45635 part 26. Distance between microphone – pump = 1 m.

**Please take this into account for the order!**

The pump setting is selected so that the most favourable sound pressure level is obtained at the relevant highest zero stroke

stroke pressure. It is therefore essential to specify the required zero stroke pressure on the order, unless it corresponds to the nominal pressure.

Observe the engineering notes on pages 28 and 30.

PV7/63-71

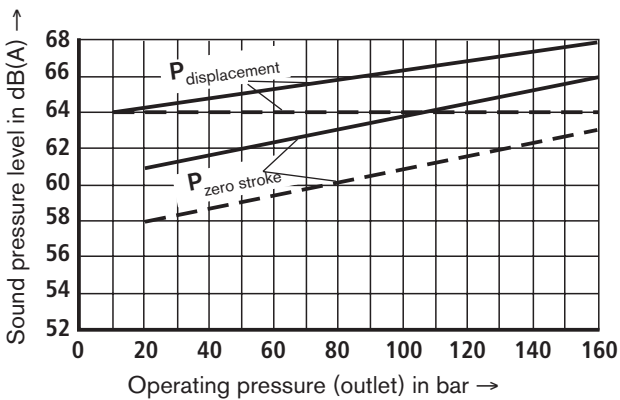

PV7/63-94

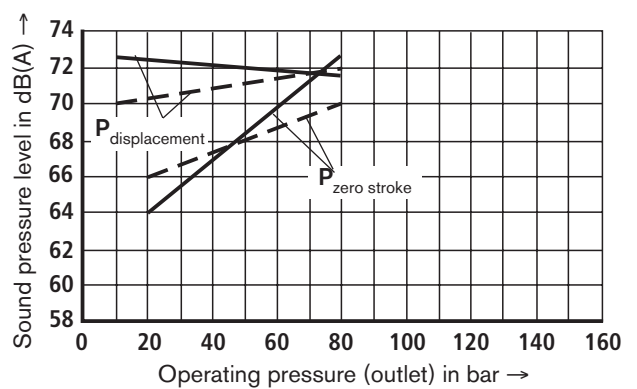

Drive speed: ———  $n = 1450 \text{ min}^{-1}$

- - - -  $n = 1000 \text{ min}^{-1}$

## Characteristic curves (measured at $n = 1450 \text{ min}^{-1}$ , $v = 41 \text{ mm}^2/\text{s}$ and $\vartheta = 50^\circ\text{C}$ )

PV7/100-118

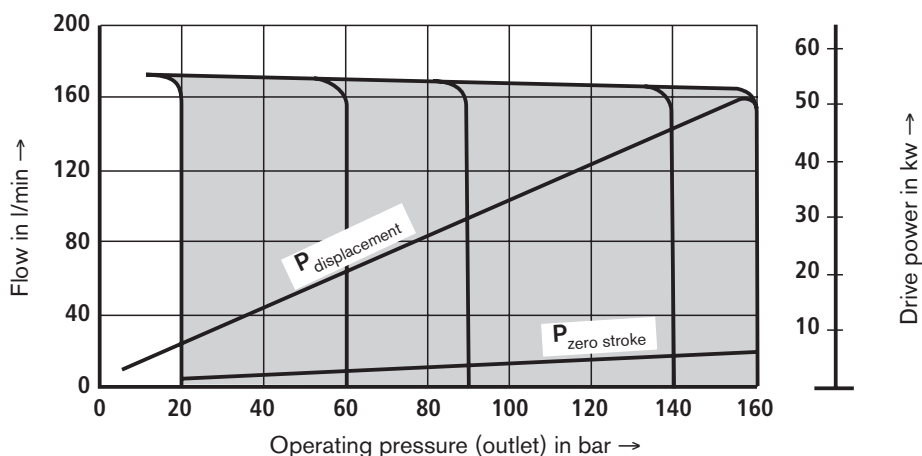

PV7/100-150

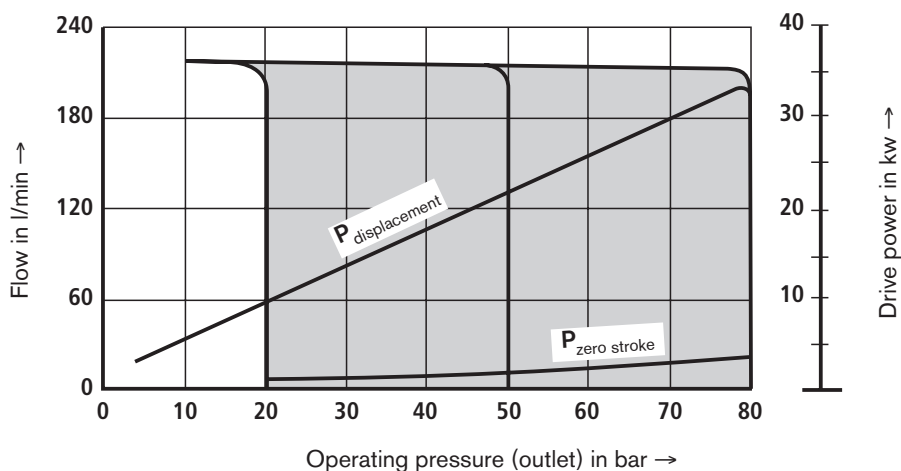

**Sound pressure level** measured in the anechoic chamber according to DIN 45635 part 26. Distance between microphone – pump = 1 m.

**Please take this into account for the order!**

The pump setting is selected so that the most favourable sound pressure level is obtained at the relevant highest zero

stroke pressure. It is therefore essential to specify the required zero stroke pressure on the order, unless it corresponds to the nominal pressure.

Observe the engineering notes on pages 28 and 30.

PV7/100-118

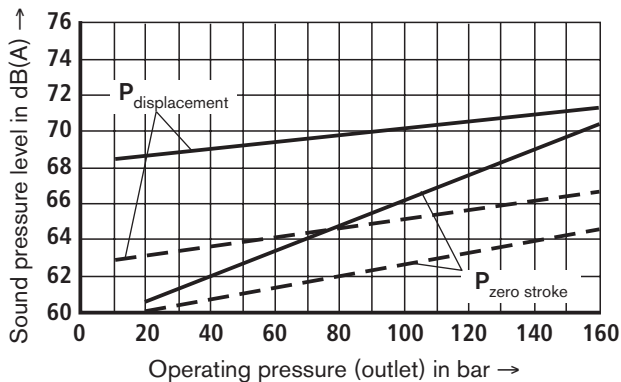

PV7/100-150

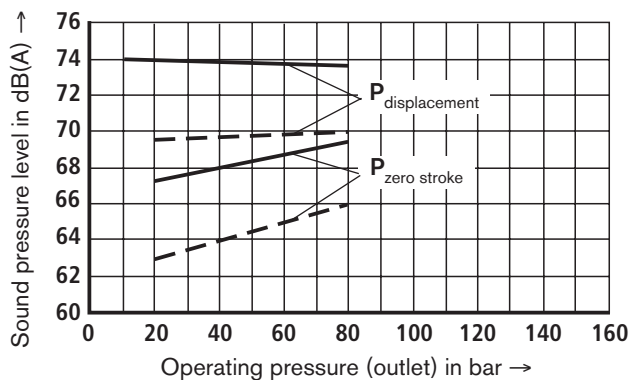

Drive speed: —  $n = 1450 \text{ min}^{-1}$

- - -  $n = 1000 \text{ min}^{-1}$

## Unit dimensions (nominal dimensions in mm)

Single pump with C, D and N controller

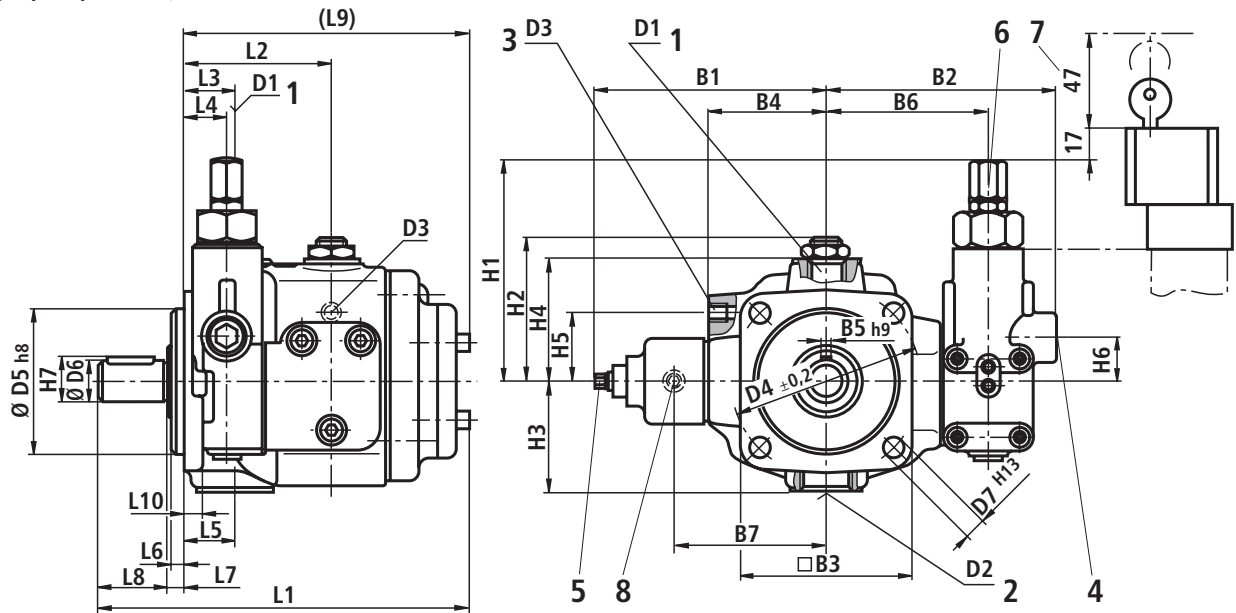

1 Pressure port <sup>1)</sup>

2 Suction port <sup>2)</sup>

3 Leakage port

4 In the case of a controller for hydraulic pressure remote control  
Ordering code ...D... and flow controller  
Ordering code ...N..., plug screw G1/4, 12 deep

5 Flow adjustment

Note on the adjustment:

- Turning clockwise: Reduction of the flow
- Turning counter-clockwise: Increase in the flow
- The set flow should not be less than 50 % of the maximum value

6 Pressure adjustment

Note on the adjustment:

- Turning clockwise: Increase in operating pressure
- Turning counter-clockwise: Reduction of the operating pressure

**Note:** The zero stroke pressure changes by approx. 19 bar with one turn of the adjustment screw.

7 Space required to remove the lock cover (the pressure can only be adjusted when the lock cover is removed)

8 Test point G1/4, 12 deep

FS	L1	L2	L3	L4	L5	L6	L7	L8	L9	L10	B1	B2	□ B3	B4	B5 <sub>h9</sub>	B6	B7
10	193	78.5	26	22	26	7	8	36	149	9	130	125	96	65	6	90	88
16	217	86	37	20	37	9	10	42	165	10	134.5	131	120	69	8	93	92
25	229	86	34	20	38	9	10	42	177	10	140.7	137	120	75	8	99	98
40	254.6	86	26.5	21.5	43	9	10	58	186.6	12	157.8	161		94	10	125	115.5
63	279	99	39	34.5	51	9	10	58	211	13	163.7	165		100	10	130	121
100	334	111	45.5	28.5	60.5	9	10	82	242	16	191.7	184.5	200	121	12	149.5	150

FS	H1	H2	H3	H4	H5	H6	H7	D1 <sup>1)</sup>	D2 <sup>2)</sup>	D3	D4±0.2	∅ D5 <sub>h8</sub>	∅ D6	D7 <sup>H13</sup>
10	117	74	58	64	37	25	22.5	G1/2	G1	G1/4	103	80	20 <sub>j6</sub>	9
16	118.5	81.5	68	72	40	26.5	28	G3/4	G1 1/4	G3/8	125	100	25 <sub>j6</sub>	11
25	118.5	91.5	92	80	40	26.5	28	G1	G1 1/2	G3/8	125	100	25 <sub>j6</sub>	11
40	118	105.5	89	94	45	26	35	G1	SAE1 1/2"	G1/2	160	125	32 <sub>k6</sub>	14
63	118	111.5	105	100	47	26	35	SAE1 1/4"	SAE 2"	G1/2	160	125	32 <sub>k6</sub>	14
100	118	123.5	126	111	52	26	43	SAE1 1/2"	SAE2 1/2"	G3/4	200	160	40 <sub>k6</sub>	18

<sup>1)</sup> Frame sizes 10, 16, 25 and 40  
Pipe thread "G..." to ISO 228/1  
Frame sizes 163 and 100, flange connection to SAE

<sup>2)</sup> Frame sizes 110, 16 and 25  
Pipe thread "G..." to ISO 228/1  
Frame sizes 140, 63 and 100, flange connection to SAE

## Dynamic characteristics of the pressure control

### Test set-up

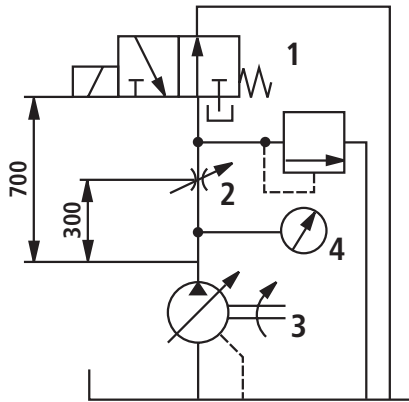

- 1 Directional valve (switching time 30 ms)
- 2 Throttle for adjusting the pressure during displacement
- 3 Hydraulic pump
- 4 Pressure measurement point

### Off-stroke control

$q_V$  displacement  $\rightarrow$   $q_V$  zero stroke

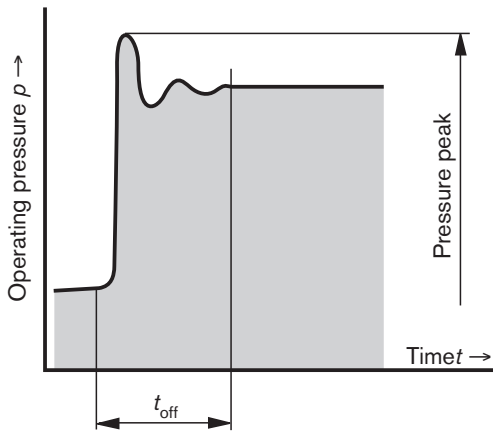

### On-stroke control

$q_V$  zero stroke  $\rightarrow$   $q_V$  displacement

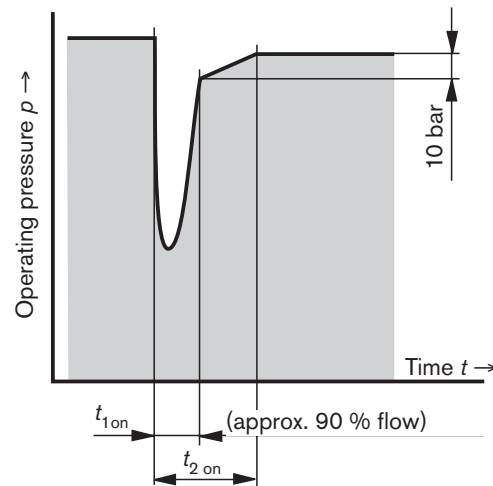

Control times	Off-stroke control time in ms (average values)						On-stroke control time in ms (average values)					
	$q_V$ displacement $\rightarrow$ $q_V$ zero stroke						$q_V$ zero stroke $\rightarrow$ $q_V$ displacement					
	20 $\rightarrow$ 160 bar		20 $\rightarrow$ 80 bar		20 $\rightarrow$ 40 bar		160 $\rightarrow$ 130 bar		80 $\rightarrow$ 60 bar		40 $\rightarrow$ 30 bar	
	$t_{off}$	$p_{max}^1$	$t_{off}$	$p_{max}$	$t_{off}$	$p_{max}$	$t_{1\ on}$	$t_{2\ on}$	$t_{1\ on}$	$t_{2\ on}$	$t_{1\ on}$	$t_{2\ on}$
10-14	100	180	-	-	150	80	60	80	-	-	60	80
10-20	-	-	100	130	150	100	-	-	60	80	50	100
16-20	100	200	-	-	120	100	50	80	-	-	50	90
16-30	-	-	100	140	150	110	-	-	50	80	50	100
25-30	100	220	-	-	120	120	80	100	-	-	70	100
25-45	-	-	100	150	120	120	-	-	80	100	80	130
40-45	100	240	-	-	120	140	70	100	-	-	60	100
40-71	-	-	100	180	120	150	-	-	80	100	80	140
63-71	150	220 <sup>2)</sup>	-	-	150	180	80	120	-	-	100	140
63-94	-	-	200	150 <sup>2)</sup>	220	150	-	-	120	150	130	210
100-118	200	220 <sup>2)</sup>	-	-	250	200	100	150	-	-	150	250
100-150	-	-	250	150 <sup>2)</sup>	280	150	-	-	150	200	180	280

<sup>1)</sup> Permissible pressure peaks

<sup>2)</sup> Pressure relief valve required for limiting pressure peaks

# Controller programme

## C controller

### Pressure controller

with mechanical pressure adjustment, ordering code ...C0-...  
(in lockable version, ordering code ...C3-...)

#### Symbol

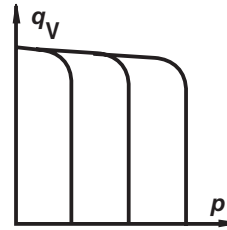
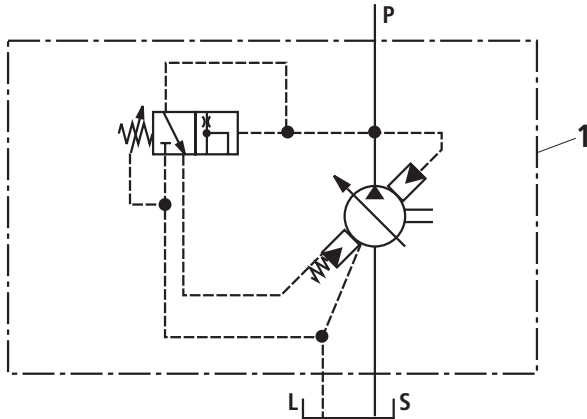

#### Order example:

1 Pump: PV7-1X/16-20RE01MC0-16  
or PV7-1X/63-94RE07MC0-08

#### Spare controller V7-1X/...CO-16

Material no. R900540478

## D controller

### Pressure controller

with hydraulic pressure remote control, ordering code ...D0-...  
(in lockable version, ordering code ...D3-...)

#### Symbol

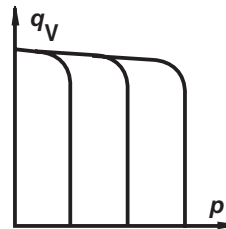
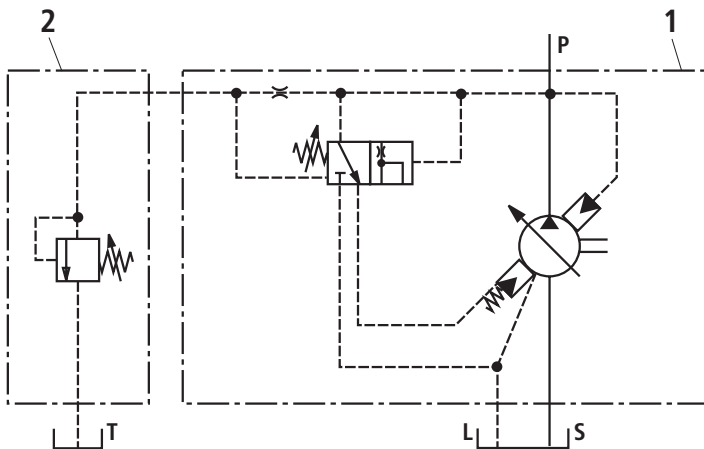

#### Order example:

1 Pump: PV7-1X/25-45RE01MD0-08  
2 Optional pressure relief valve; must be ordered separately

The remote control line between controller and pressure relief valve (2) should not be longer than 2 m.

**Note:** The zero stroke pressure results from the addition of the pressures set on the pump and on the pressure relief valve. The remote control port must not be plugged, since otherwise, the pump does not destroke!

#### Spare controller V7-1X/...DO-16

Material no. R900540596

## Controller programme

### N controller

#### Flow controller

with mechanical flow adjustment, ordering code ...N0-...  
(in lockable version, ordering code ...N3-...)

#### Symbol

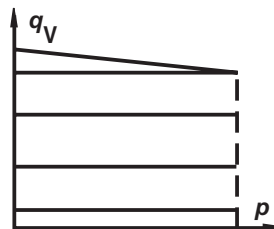
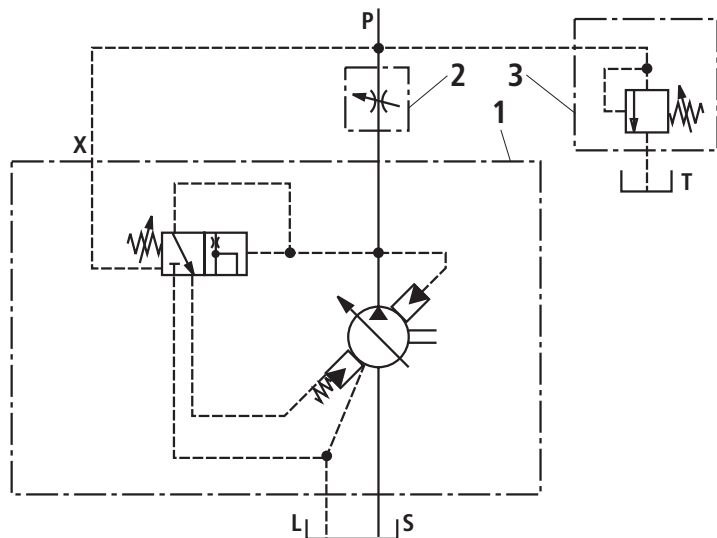

#### Order example:

- 1 Pump: PV7-1X/16-20RE01MN0-16  
or PV7-1X/63-94RE07MN3-08
- 2 Optional metering orifice (e.g. throttle to RE 27219)
- 3 Optional pressure relief valve  
(this valve is required, since the control is not related to the zero stroke)

Items 2 and 3 must be ordered separately.

The control line between controller port "X" and the metering orifice should not be longer than 1.5 m.

Differential pressure approx. 13 bar

#### Spare controller V7-1X/...NO-16

Material no. **R900543510**



# Controller programme

## W controller

### Pressure controller

with electrically switchable 2-stage pressure adjustment element, ordering code ...W0-...

### Symbol

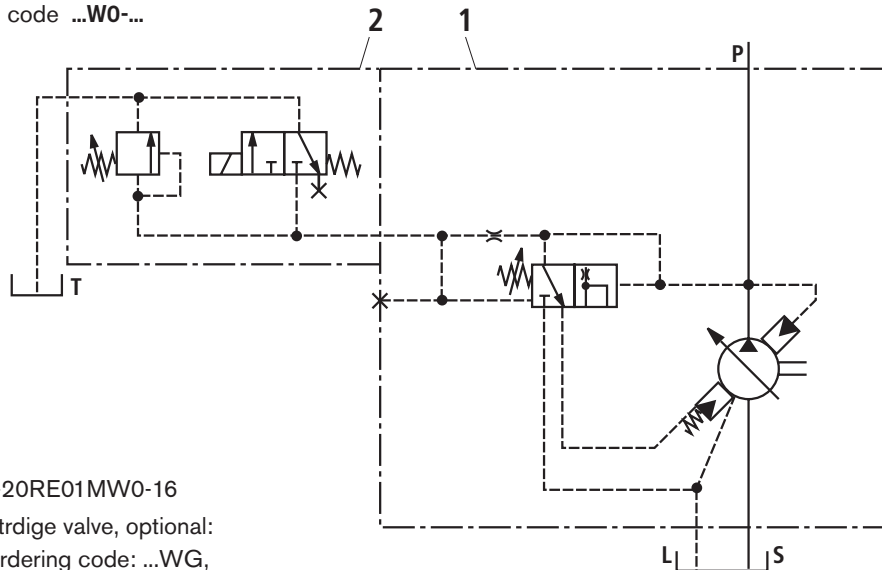

### Order example:

1 Pump: PV7-1X/16-20RE01MW0-16

2.1 3/2 directional cartridge valve, optional:  
Normally closed, ordering code: ...WG,  
includes 3WE 4 C1 XK/EG24N9K4  
Material no. **R900712507**

Normally open, ordering code ...WH,  
includes valve 3WE 4 U1XK/EG24N9K4  
Material no. **R900712509**

2.2 Pressure relief valve to RE 25710

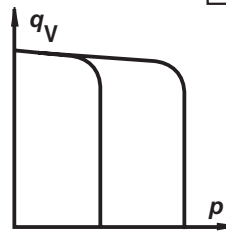

## Unit dimensions (nominal dimensions in mm)

### W controller

For further unit dimensions, see page 13.

Frame size	B1	H1	H2
10	189	187.5	77.5
16	192	189	79
25	198	189	79
40	224	188.5	8.5
63	229	188.5	8.5
100	248.5	188.5	78.5

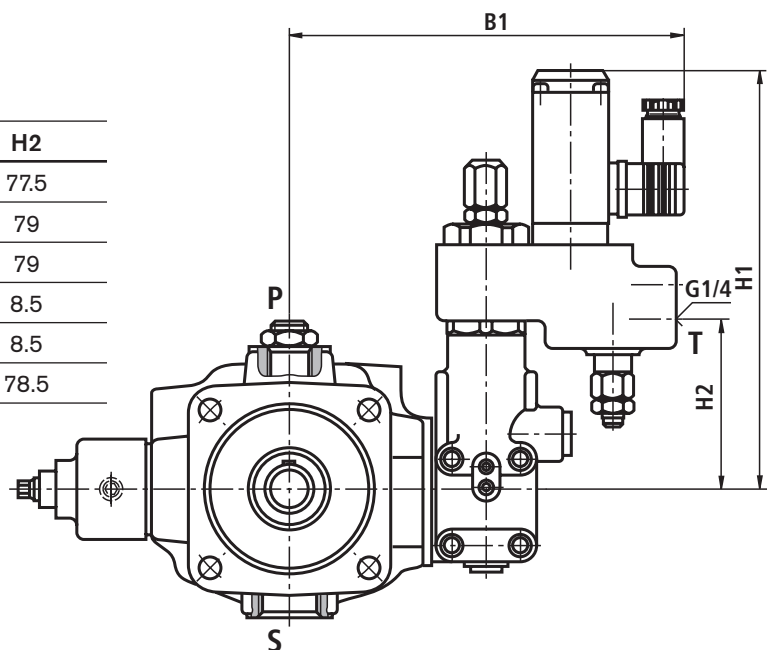

## Controller programme

### Hydraulic start-up aid (K plate)

#### Sandwich plate

with unloading valve for starting up at lowest zero stroke pressure.

Zero stroke pressure approx. 20 bar (depending on application)

Ordering code: ...5-...

(in lockable version, ordering code ...7-...)

#### Note

Not suitable as 2-stage control!

#### Symbol

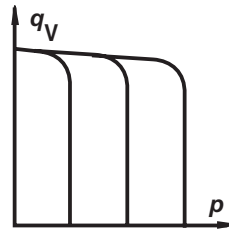
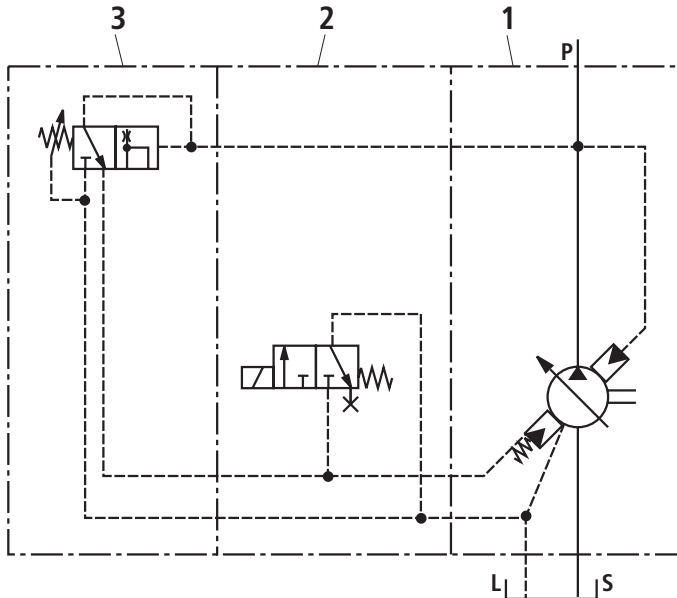

#### Order example:

1 Pump: PV7-1X/40-71RE37MC5-08

2 3/2 directional cartridge valve, optional:

Normally closed, ordering code: ...WG,  
includes valve 3WE 4 C1 XK/EG24N9K4  
Material no. **R900712507**

Normally open, ordering code ...WH,  
includes valve 3WE 4 U1XK/EG24N9K4  
Material no. **R900712509**

The figure shows type ...WG

3 Optional C, D or N controller

#### Accessories for conversions

From controller variant ...0-... to ...5-...:

Plate V7-1X/.K, material no. **R900854415**

## Unit dimensions (nominal dimensions in mm)

### K plate

For further unit dimensions, see page 13.

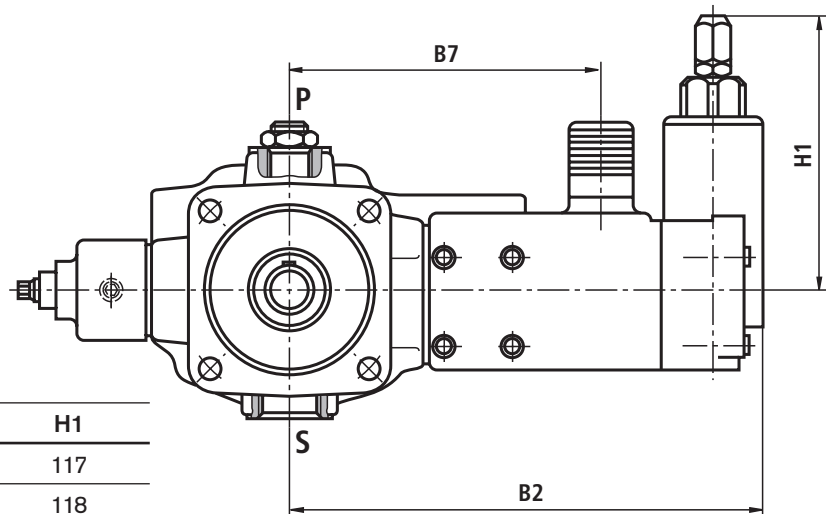

Frame size	B2	B7	H1
10	204.5	143.5	117
16	207.5	146.5	118
25	214	153	118
40	240	179	118
63	244.5	183.5	118
100	264	203	118

## Controller programme

### Flow/pressure controller (Q plate)

#### Sandwich pump

– For combining a flow controller with a pressure-compensated pump

– With built-on standard flow controller

Ordering code: ...6-...

(in lockable version, ordering code ...8-...)

#### Symbol

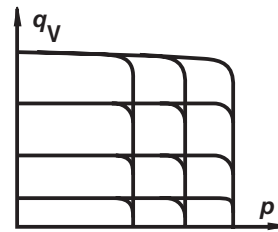
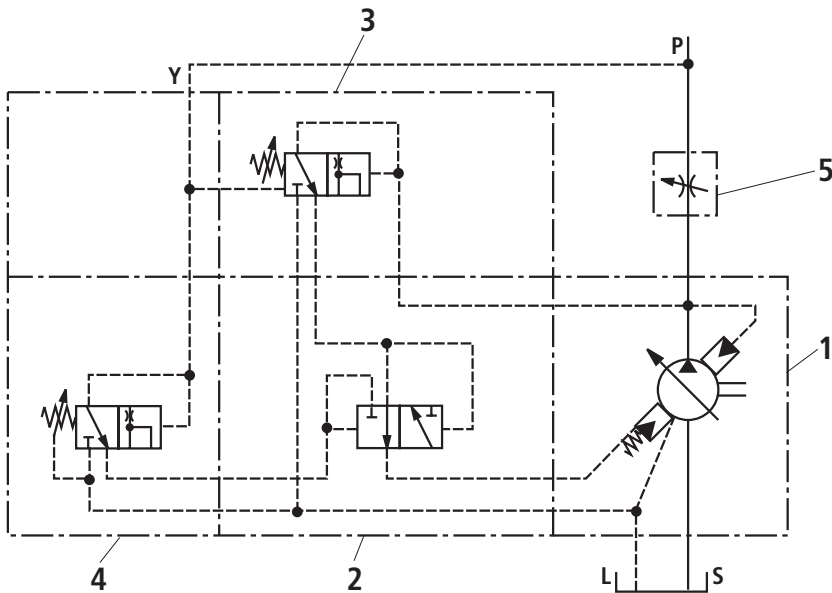

#### Order example:

- 1 Pump: PV7-1X/63-712RE07MC6-16
- 2 Sandwich plate for combining the pressure controller and the flow controller function
- 3 Flow controller as described on page 16
- 4 Pressure controller optionally of types C, D, E or W as described on pages 15 and 16
- 5 Optional metering orifice (e.g. throttle to RE 27219), must be ordered separately

The control line between controller port "Y" and the metering orifice should not be longer than 1.5 m.

#### Accessories for conversions

From controller variant ...0-... to ...6-... , includes items 2 and 3:

Plate V7-1X/...Q

Material no. **R900860093**

## Unit dimensions (nominal dimensions in mm)

### Q plate

For further unit dimensions, see page 13.

Frame size	B2	H1
10	173.5	117
16	176.5	118.5
25	182.5	118.5
40	208.5	118
63	213.5	118
100	233	118

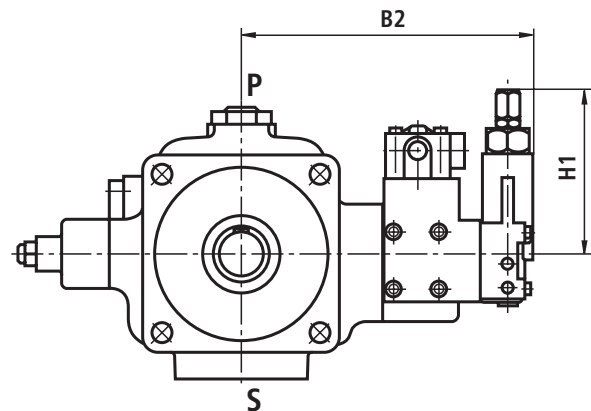

## Lock

Material no.: R900844598

This lock is included in the scope of supply for pumps with controller options of versions ...3..., ...7... or ...8...

### Functional description

After unlocking (by turning the key clockwise) the complete lock cover can be removed from the controller, which allows free access to the adjustment element.

To lock, the lock cover must be placed over the controller adjustment element and pressed home, the lock cylinder pressed down and the key turned to the left.

**The lock can be easily retrofitted to a standard pump.**

- Unscrew the cap nut from the controller adjustment element.
- Fit the cap nut that is provided with the key
- Plug on the lock as shown in the functional description.

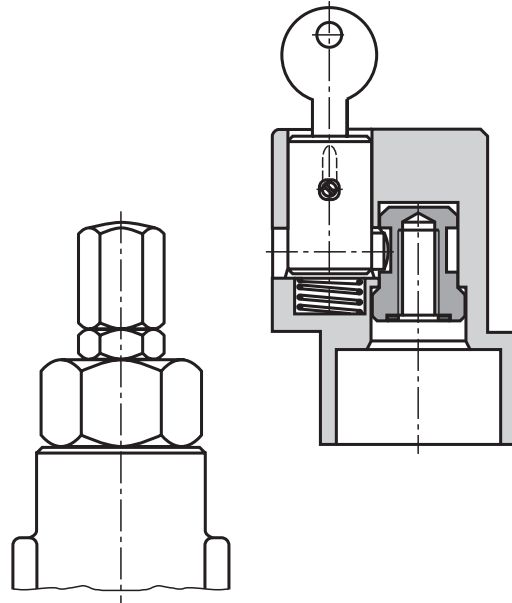

## Notes on the engineering of multiple pumps

- PV7 pumps can be combined as a standard. Each pump is fitted with a splined, second shaft end.
- When the PV7 is operated as fixed displacement pump, the fixed displacement pump must be used as rear pump.
- The general technical data are the same as that of the single pump (see page 6).
- The pump that is subjected to higher loads (pressure x flow) should be the first pump stage.
- When several pumps are combined, the torques that occur can reach impermissibly high values. The sum of torques must not exceed the permissible values (see table)
- Combination parts must be listed as separate items on the order.
- The combination parts include the required seals and screws

### Single pump

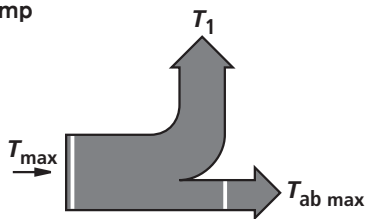

PV7 frame size	Max. perm. input torque $T_{max}$	Max. perm. output torque $T_{out max}$
10	90	45
16	140	70
25	180	90
40	280	140
63	440	220
100	680	340

Calculation example:

- $V$  = Displacement volume in  $cm^3$
- $\eta_{hydr.-mech.}$  = Hydraulic-mechanical efficiency
- $T$  = Torque in Nm
- $\Delta p$  = Pressure in bar

### Combination pump

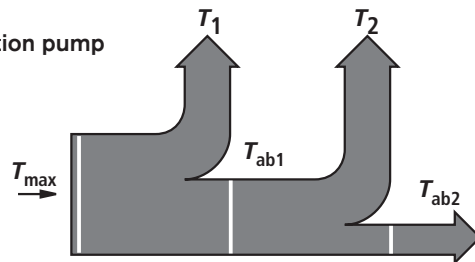

Pump combination: P2V7/25-30... + V7/25-30  
 Required max. pressure:  $p_n = 160$  bar

$$T = \frac{\Delta p \times V \times 0.0159}{\eta_{hydr.-mech.}} \quad (\text{Nm})$$

$$T_{1,2} = \frac{160 \times 30 \times 0.0159}{0.85} \quad (\text{Nm})$$

$$T_{1,2} = 90 \text{ Nm} \leq T_{off max}$$

$$T = T_1 + T_2 = 180 \text{ Nm} \leq T_{max}$$

The pump combination can be operated on the basis of the calculated data .

## Combination options

All pumps of type PV7 can be combined. Each pump with E-shaft is provided with an output spline.

All combinations of a PV7 + optional rear pump are sealed against each other by means of the shaft seal ring of the rear pump. The seal is direction-related. In the case of more strin-

gent requirements with regard to a reliable separation of media, please consult the technical sales department.

Possible combinations and the material no. of the required combination parts can be found in the following table.

Rear pump	Front pump			
	PV7-1X/10	PV7-1X/16/25	PV7-1X/40/63	PV7-1X/100
PV7-1X/06-...RA01M...	R900540811	R900540812	R900540814	R900543034
PV7-1X/10-...RE01M...	R900540811	R900540812	R900540814	R900543034
PV7-1X/16-...RE01M...	-	R900540813	R900540815	R900543035
PV7-2X/20-...RA01M...	-	R900540813	R900540815	R900543035
PV7-1X/25-...RE01M...	-	R900540813	R900540815	R900543035
PV7-1X/40-...RE37M...	-	-	R900540816	R900543036
PV7-1X/63-...RE07M...	-	-	R900540816	R900543036
PV7-1X/100-...RE07M...	-	-	-	R900543037
PGF1-2X/...RE01VU2	R900857584	R900857585	-	-
PGF2-2X/...RJ...VU2	R900541209	R900541210	R900541203	R900544959
PGF3-3X/...RJ...VU2	-	R900888267	R900880623	R900880624
PGP2-2X/...RJ20VU2	R900541209	R900541210	R900541203	R900544959
PGP3-3X/...RJ...VU2	-	R900888267	R900880623	R900880624
PGH2-2X/...RR...VU2	R900541209	R900541210	R900541203	R900544959
PGH3-2X/...RR...VU2	R900541209	R900541210	R900541203	R900544959
PGH4-2X/...RR...VU2	-	-	R900876578	R900876576
PVV/Q1/2-1X/...RJ15...	-	R900888267	R900880623	R900880624
PVV/Q4/5-1X/...RJ15...	-	-	R900876023	R900875983
AZPF....	R900541209	R900541210	R900541203	R900544959
PR4-1X/0,40...2,00-...WG...	R900541204	R900541205	R900541206	-
PR4-3X/1,60...20,00-...RG...	R900541214	-	-	-
PR4-3X/1,60...20,00-...RA...	-	R900541207	R900541208	R900543767
A10VSO10...U	R900541209	R900541210	R900541203	R900544959
A10VSO18...U	R900541209	R900541210	R900541203	R900544959
A10VO28...S	-	R900888267	R900880623	R900880624

## Ordering codes of multiple pumps

P2	V7/100-150	C0	+	V7/100-150	C0	R	E	07	+		07	E4	*	
Double = P2	Series of the first pump	Size of the first pump	Controller of the first pump	Series of the second pump	Size of the second pump	Controller of the second pump	Direction of rotation							Further details in clear text
														Mounting flange of the first pump
														Pipe connection of the second pump
														Shaft version of the second pump (if required) <sup>1)</sup>
														Pipe connection of the first pump!
														Shaft version of the first pump

<sup>1)</sup> With PGF2 and PGF3

Triple and quadruple pumps are coded by analogy!

Pump combination P2V7... + V7/... (nominal dimensions in mm)

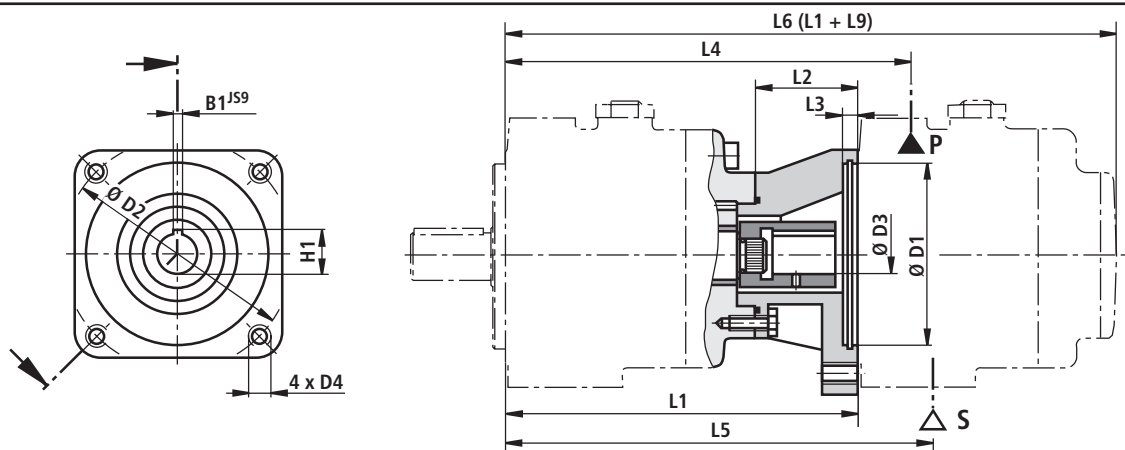

1st pump FS	2nd pump FS	L1	L2	L3	ØD1	ØD2	ØD3	D4	H1	B1	L4	L5	L6
10	06	182	50	8	80	103	20	M8	22.8	6	199	202.5	283
	10	182	50	8	80	103	20	M8	22.8	6	208	208	331
16	06	200	55	8	80	103	20	M8	22.8	6	217	220.5	301
	10	200	55	8	80	103	20	M8	22.8	6	226	226	349
	16	208	63	10	100	125	25	M10	28.3	8	245	245	373
	20	208	63	10	100	125	25	M10	28.3	8	238	233	343
25	06	212	55	8	80	103	20	M8	22.8	6	229	232.5	313
	10	212	55	8	80	103	20	M8	22.8	6	238	238	361
	16	220	63	10	100	125	25	M10	28.3	8	257	257	385
	20	220	63	10	100	125	25	M10	28.3	8	245	245	354
	25	220	63	10	100	125	25	M10	28.3	8	254	258	397
40	06	221.6	55	8	80	103	20	M8	22.8	6	238.6	242.1	322.6
	10	221.6	55	8	80	103	20	M8	22.8	6	247.6	247.6	370.6
	16	229.6	63	10	100	125	25	M10	28.3	8	266.6	266.6	394.6
	20	229.6	63	10	100	125	25	M10	28.3	8	254.6	254.6	363.6
	25	229.6	63	10	100	125	25	M10	28.3	8	263.6	267.6	406.6
	40	246.6	80	10	125	160	32	M12	35.3	10	273.1	289.6	433.2
63	06	244.5	55	8	80	103	20	M8	22.8	6	261.5	265	345.5
	10	244.5	55	8	80	103	20	M8	22.8	6	270.5	270.5	393.5
	16	252.5	63	10	100	125	25	M10	28.3	8	289.5	289.5	417.5
	20	252.5	63	10	100	125	25	M10	28.3	8	277.5	277.5	386.5
	25	252.5	63	10	100	125	25	M10	28.3	8	286.5	290.5	429.5
	40	269.5	80	10	125	160	32	M12	35.3	10	296	312.5	456.1
	63	269.5	80	10	125	160	32	M12	35.3	10	308.5	320.5	480.5
100	06	276.5	55	8	80	103	20	M8	22.8	6	293.5	297	277.5
	10	276.5	55	8	80	103	20	M8	22.8	6	302.5	302.5	425.5
	16	284.5	63	10	100	125	25	M10	28.3	8	321.5	321.5	449.5
	20	284.5	63	10	100	125	25	M10	28.3	8	309.5	309.5	418.5
	25	284.5	63	10	100	125	25	M10	28.3	8	318.5	322.5	461.5
	40	301.5	80	10	125	160	32	M12	35.3	10	328	344.5	488.1
	63	301.5	80	10	125	160	32	M12	35.3	10	340.5	352.	515.5
	100	321.5	100	10	160	200	40	M16	47.3	12	367	382	563.5

**Pump combination P2V7... + GF2 / GP2 / GH2 / GH3 / AZPF / A10VSO (nominal dimensions in mm)**

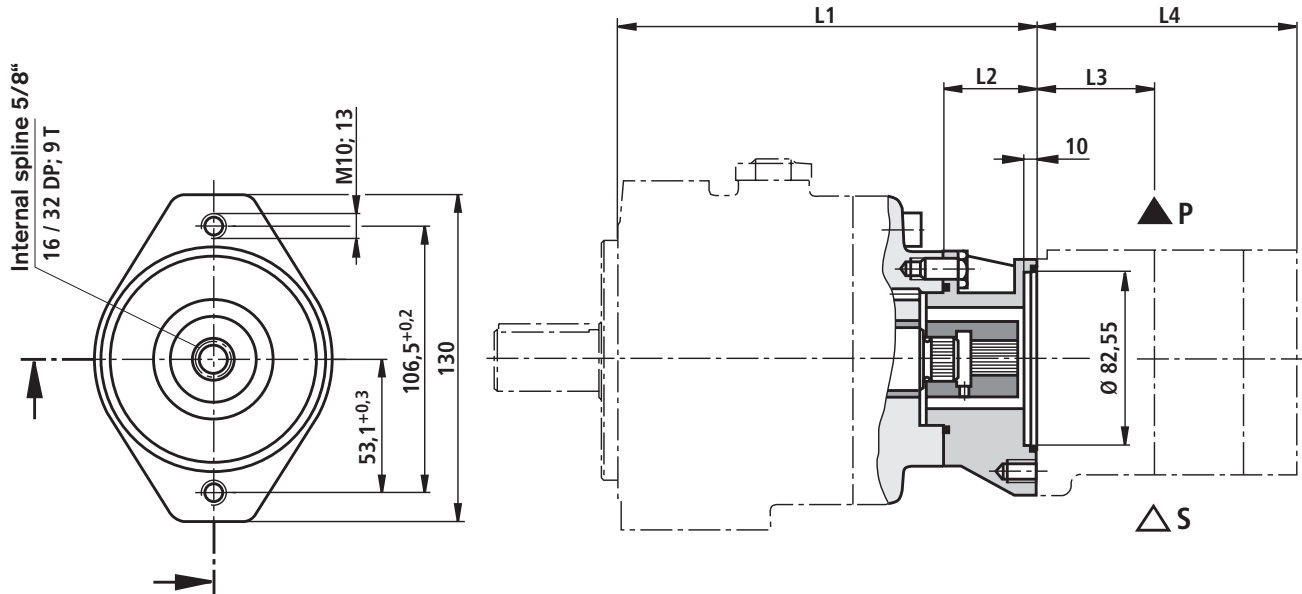

PV7 frame size	L1	L2
10	168	36
16	192	47
25	204	47
40	213.6	47
63	236.5	47
100	268.5	47

PGF2/PGP2 size	L3	L4
006	65	116
008	67	119.5
011	69.5	125
013	72	130
016	74.5	135
019	77.5	141
022	80.5	147

PGH2 size	L3	L4
003	51	102.5
005	54	110
006	55.5	112.5
008	57	116

PGH3 size	L3	L4
011	60	121.5
013	62.5	126.5
016	65	131.5

AZPF size	L3	L4
004	40	85
005	41	87.5
008	43	91.5
011	47	96.5
014	47.5	101.5
016	47.5	105
019	47.5	110
022	55	115.5

A10VSO size	L3	L4
010	148 <sup>1)</sup>	164; 179 <sup>2)</sup>
018	145	195

<sup>1)</sup> Pipe connections axial

<sup>2)</sup> Depending on controller (see RE 92713)

Pump combination P2V7... + GF3 / GP3 / VV1 / VV2 / GH4 / A10VO28 (nominal dimensions in mm)

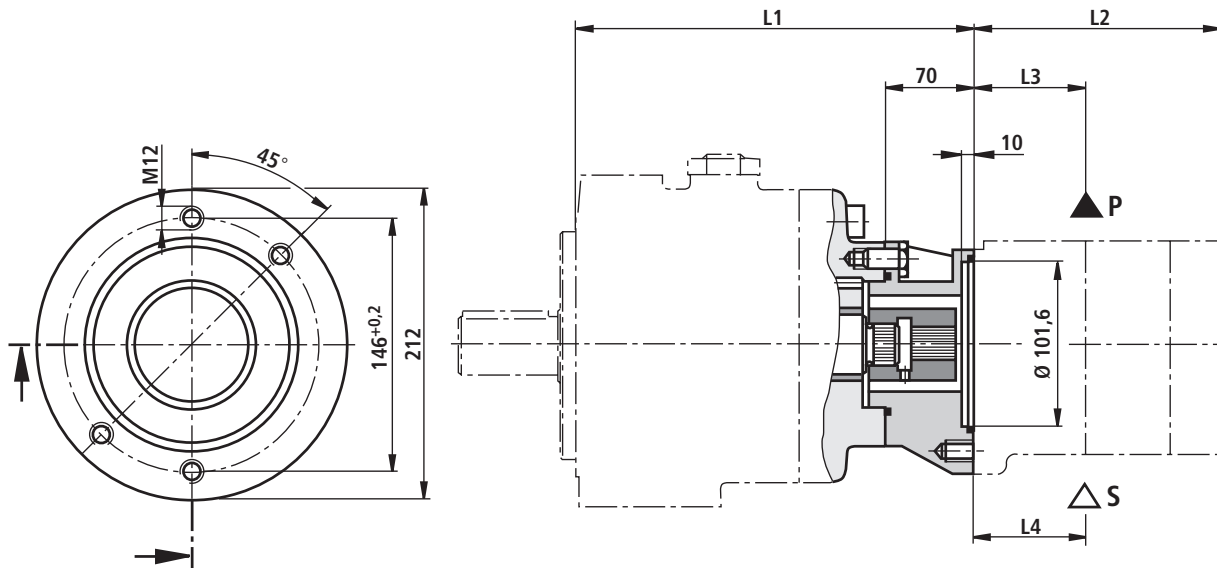

PV7 frame size	L1
16	215
25	227
40	237
63	259.5
100	291.5

PGF3/PGP3 size	L2	L3;L4
020	144.5	79.5
022	146.5	80.5
025	150.5	82.5
032	159.5	87
040	169.5	92
050	182.5	98.5

PGH4 size	L2	L3,L4
020	147	70.5
025	152	73
032	159	76.5
040	166	80
050	176	85
063	190	92
080	204	99
100	224	109

PVV.UMB	L2	L3 (P)	L4 (S)
PVV1	156	133	63.5
PVV2	163	38.1	120.6

A10VO size	L2	L3	L4
028	194	164.5	164.5



**Pump combination P2V7/63... + VV4 / VV5 (nominal dimensions in mm)**

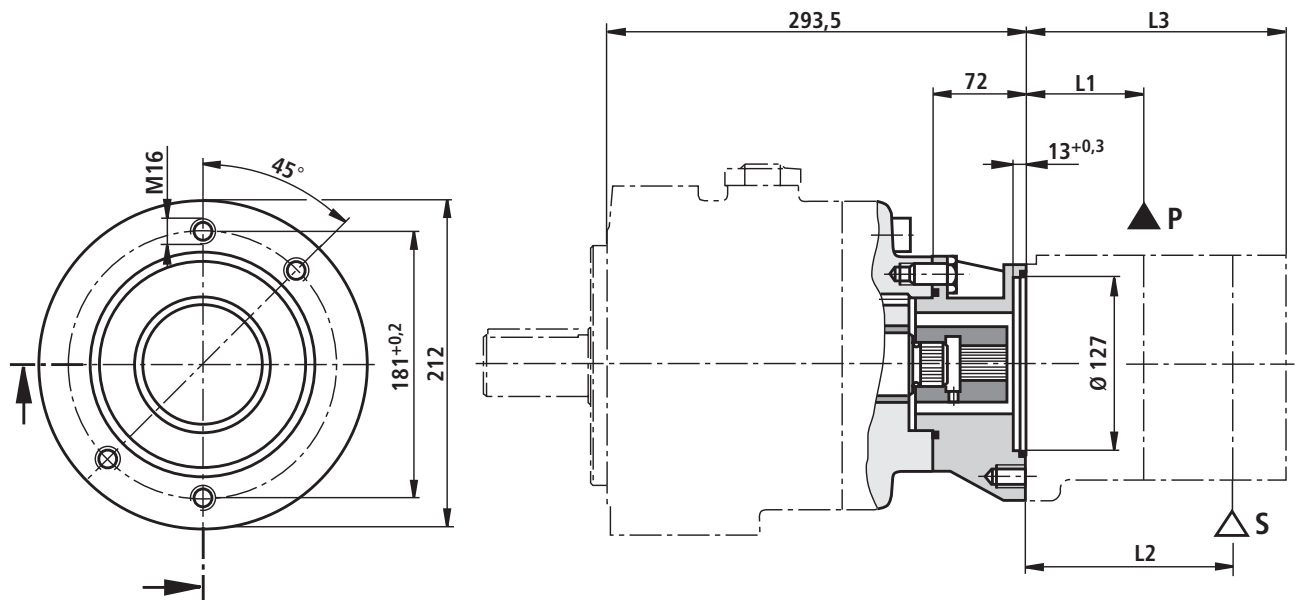

	L1	L2	L3
PVV4...UMC	38.1	125.5	186
PVV5...UMC	42.9	153.2	216

**Pump combination P2V7/100... + VV4 / VV5 (nominal dimensions in mm)**

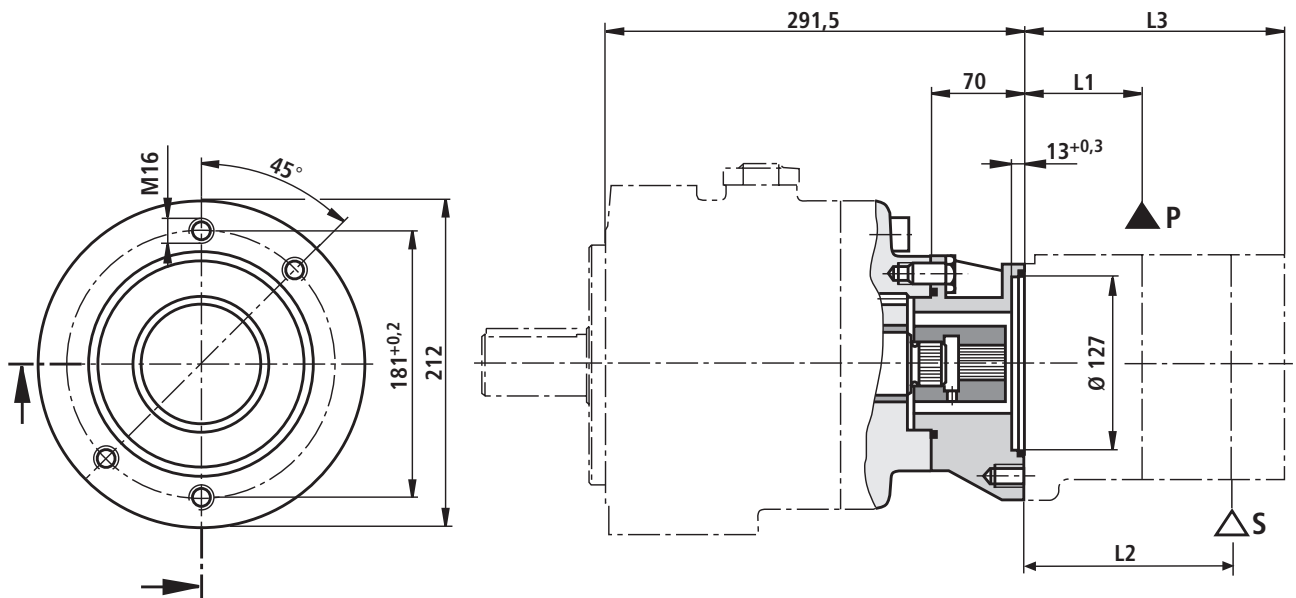

	L1	L2	L3
PVV4...UMC	38.1	125.5	186
PVV5...UMC	42.9	153	216

### Pump combination P2V7... + GF1... (nominal dimensions in mm)

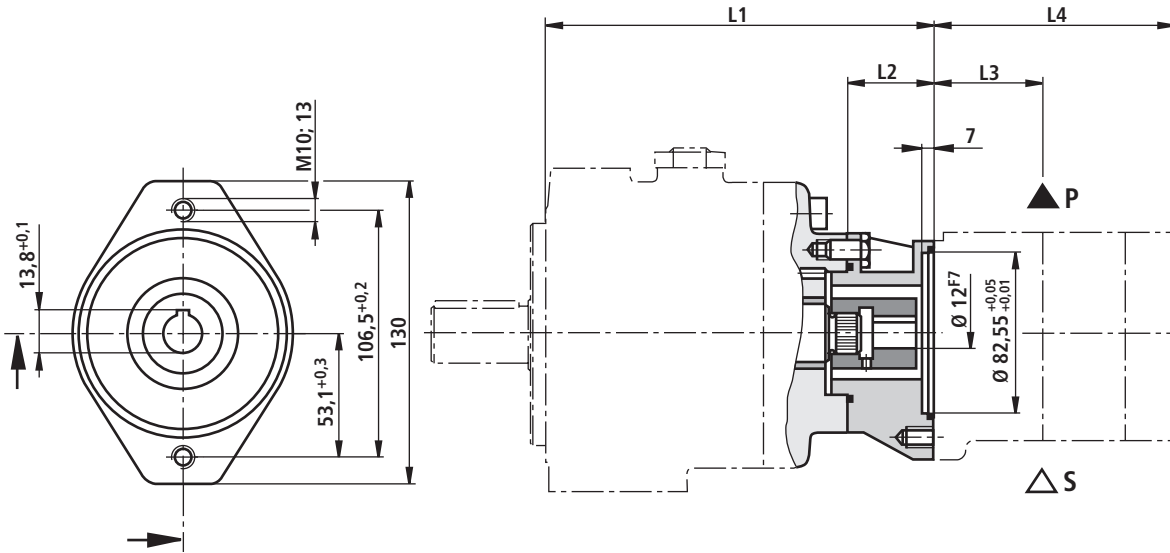

PV7 frame size	L1	L2
10	168	36
16	192	47
25	204	47

GF1 size	L3	L4
1.7	8.6	86
2.2	48.6	86
2.8	49.7	88.6
3.2	50.5	89.9
4.1	52.4	93.6
5.0	54.2	97.3

### Pump combination P2V7... + PR4-Mini (nominal dimensions in mm)

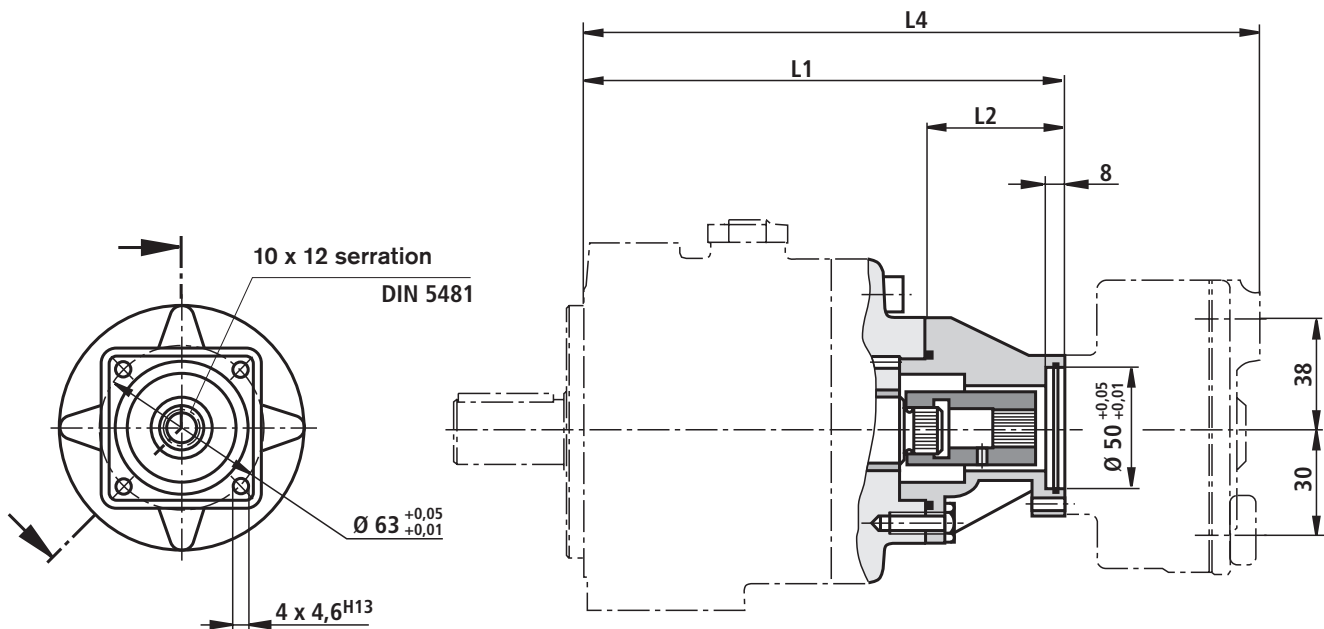

PV7 frame size	L1	L2	L4
10	178	46	247
16	208	63	277
25	220	63	289

PV7 frame size	L1	L2	L4
40	229.6	63	298.6
63	252.5	63	321.5
100	284.5	63	353.5

**Note:** The suction port of PR4 should be located above the pressure port!

## Pump combination P2V7... + PR4 standard (nominal dimensions in mm)

### PV7/10... + PR4 standard

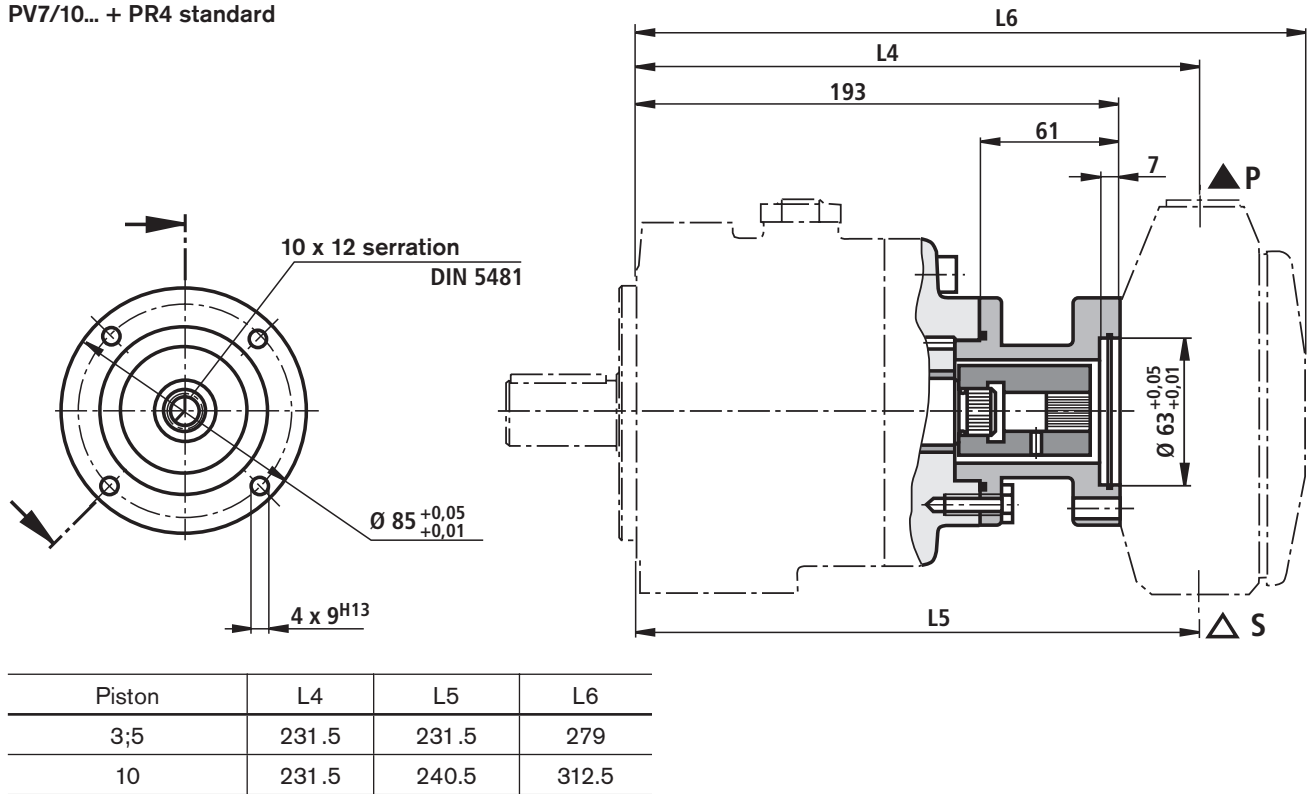

### PV7/16... to PV7/100... + PR4 standard

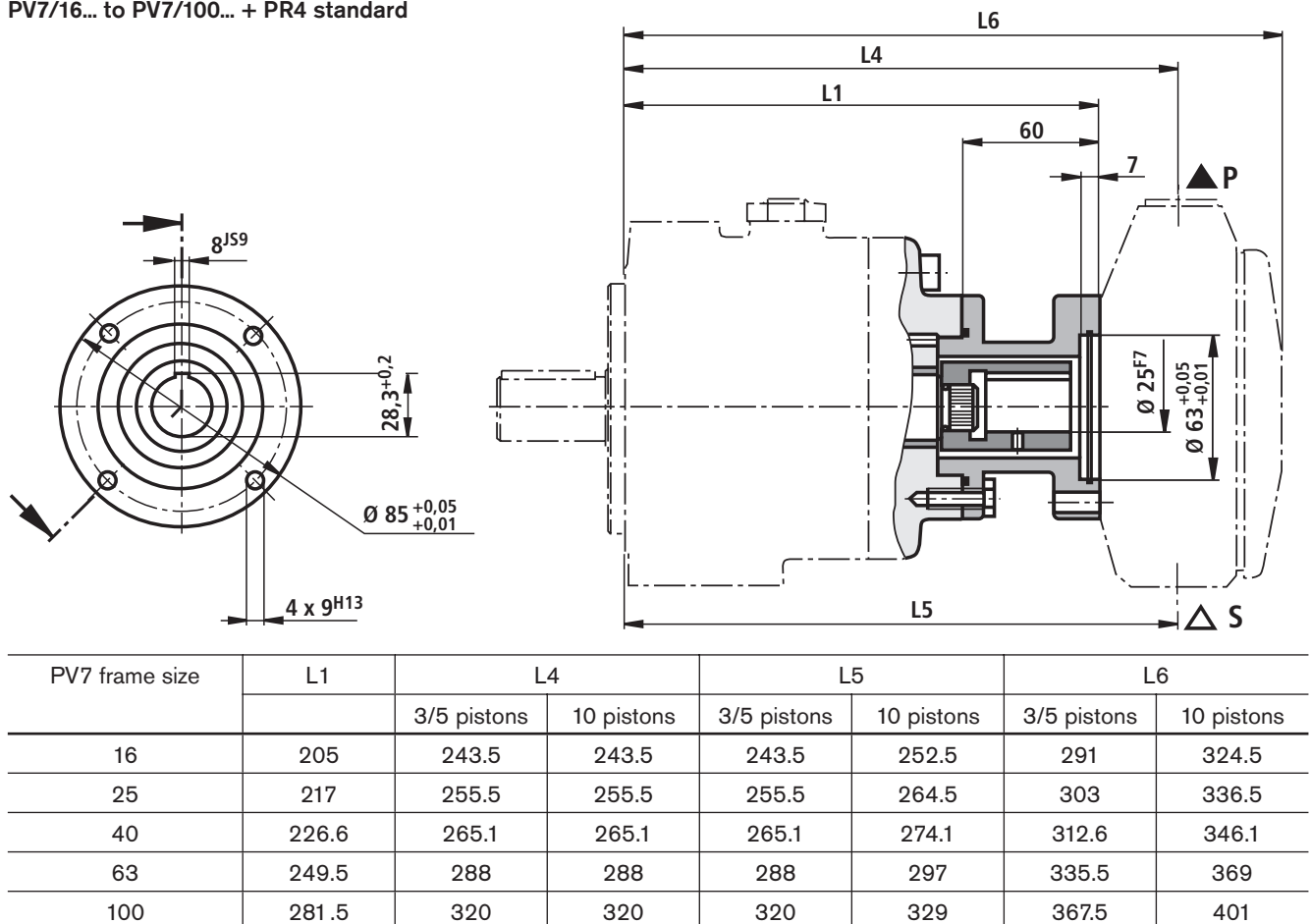

## SAE connection flanges, max. operating pressure 210 bar (3000 PSI)

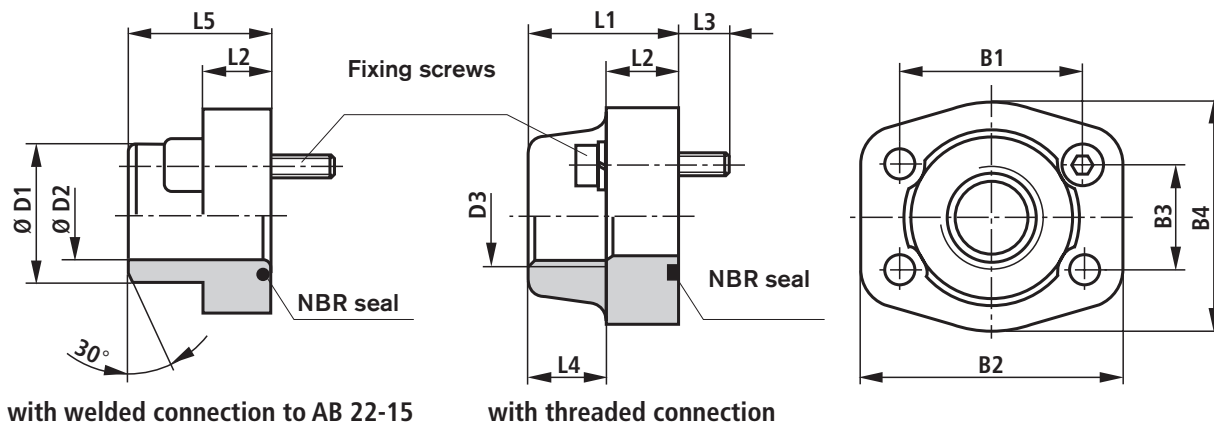

with welded connection to AB 22-15

with threaded connection

The material nos. include the flange, the O-ring and the fixing screws.

Pipe thread "G" to ISO 228/1

Size	Seal material	Material no.		For pump type	
		Welded connection	Threaded connection	Suction port	Pressure port
1 1/4	NBR	R900012946	R900014153	-	PV7/63-...
1 1/2	NBR	R900013501	R900014827	PV7/40-...	PV7/100-...
2"	NBR	R900013502	R900014829	PV7/63-...	-
2 1/2"	NBR	R900013503	R900024205	PV7/100-...	-

Size	B1	B2	B3	B4	D1	D2	D3	L1	L2	L3	L4	L5	Fixing screws
1 1/4	58.7	79	30.2	68	38	30	G1 1/4	41	21	18	22	42	M10-8.8
1 1/2	69.9	95	35.7	76	42	36	G1 1/2	44	25	18	24	57	M12-8.8
2"	77.8	102	42.9	90	61	49	G2	45	25	18	26	46	M12-8.8
2 1/2"	88.9	114	50.8	104	76	62	G2 1/2	50	25	18	30	50	M12-8.8

### Engineering notes

Comprehensive notes and suggestions can be found in The Hydraulic Trainer, Volume 3, RE 00281, "Planning and design of hydraulic systems".

When using vane pumps, we recommend that the following notes are observed in particular:

#### - Technical data

All technical data mentioned depend on manufacturing tolerances and are valid under certain boundary conditions. Please note that small tolerances are therefore possible and that different boundary conditions (e.g. viscosity) can also result in changes in the technical data.

#### - Characteristic curves

Characteristic curves for flow and absorbed power. Please take the possible maximum operating data into account when dimensioning the drive motor.

#### - Noise/sound pressure level

The sound pressure level values given on pages 6 to 11 were measured in accordance with DIN 45635 part 26.

This means that only the sound emission of the pump is shown. Ambient influences (such as place of installation, piping, etc.) were eliminated. The values are valid for only one pump.

If, for example, two pumps of the same frame size are operated under the same load conditions, the noise level increases according to the following formula:

$$L_{\Sigma} = 10 \lg (10^{0.1 \cdot L_1} + 10^{0.1 \cdot L_2})$$

$L_{\Sigma}$  = Total noise level

$L_1 \dots L_i$  = Sound pressure level of the individual pump

Example: PV7/16 + PV7/16

$$p = 120 \text{ bar}$$

$$L_1 = 56 \text{ dB(A)}$$

$$L_2 = 56 \text{ dB(A)}$$

$$L_{\Sigma} = 10 \log (10^{0.1 \cdot 56} + 10^{0.1 \cdot 56})$$

$$= 59.01 \text{ dB(A)}$$

## Engineering notes

---

### Caution!

The power unit design and influences at the final place of installation of the pump result in the fact that the sound pressure level is usually 5 to 10 dB(A) higher than the value of the pump alone.

### Leakage oil

The external leakage fluid of the pump dissipates a part of the frictional heat. The leakage fluid should be directed with low line resistance directly into the tank. The distance between the leakage line and the suction line must be sufficiently large so that the returning leakage fluid **cannot** be directly re-aspired. The flow of average, external leakage is shown on page 5. These values must not be used for dimensioning the tanks. The relevant variable for the selection of the tank size is the zero stroke power (see pages 7 to 12).

### Leakage fluid cooler

The values for external leakage fluid given on page 6 are average values that are valid for continuous operation. When the pump goes off stroke, the leakage fluid volume briefly increases due to the pilot fluid of the controller. Reductions in cross-sections, long leakage lines, or also leakage fluid coolers can lead to impermissibly high pressure peaks. Suitable measures, e.g. a check valve in the by-pass must prevent the leakage fluid pressure ( $p_{\max} = 2 \text{ bar}$ ) from exceeding the permissible values. Otherwise, the shaft seal ring could be damaged.

## Commissioning notes

---

### Bleeding

- All vane pumps of type PV7 are self-priming.
- Before initial commissioning, the pump must be bled in order to protect it against damage.
- We recommend that the housing be filled via the leakage port for initial commissioning. Observe the filter rating! This increases the operational reliability and prevents wear under unfavourable installation conditions.
- Should the pump not displace bubble-free oil after approx. 20 s, check the system again. After the operating values have been reached, inspect the pipe connections for leakage and check the operating temperature.

### Commissioning

- Check that the system has been properly and thoroughly assembled.
- Observe the direction-of-rotation arrows of the motor and the pump.
- Let the pump start up under no-load conditions and let it displace fluid at zero pressure for some seconds in order to provide sufficient lubrication.
- **In no case may the pump be operated without fluid!**

### Important notes

- Adjustments, servicing and repairs of the pump may only be carried out by authorised, trained and instructed personnel!
- The pump may only be operated with the permissible data.
- The pump may only be operated when in perfect condition!
- When carrying out any work on the pump (e.g. installation or removal), the system must be de-energised and de-pressurised!
- Unauthorised conversions or changes to the system, which affect safety and function, are not permitted!
- Fit protective equipment (e.g. coupling guard)!
- Do not remove any existing protective guards!
- Strictly observe generally valid safety regulations and regulations for the prevention of accidents!

## Installation notes

---

### Drive

El. motor + pump mounting bracket + coupling + pump

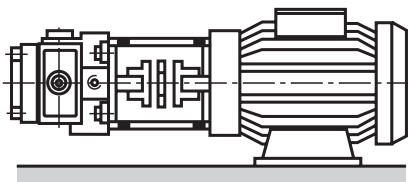

### Caution!

- Radial and axial forces acting on the pump drive shaft are not permitted!
  - Motor and pump must be exactly aligned
  - Use a flexible drive coupling

## Installation notes

### Installation positions

- Horizontal position preferred

B3

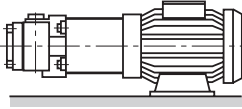

B5

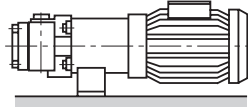

V1

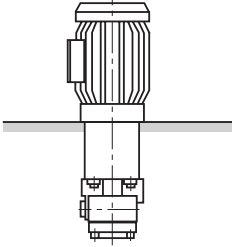

### Fluid tank

- Adapt the useful capacity of the tank to the operating conditions.

### Caution!

- The permissible fluid temperature must not be exceeded → if required, provide cooler!

### Lines and connections

- Cut off at an angle of 45°.
- Remove protective plug from the pump.
- We recommend the use of seamless precision steel pipes according to DIN 2391 and removable pipe connections.
- Select the clear width of the pipes according to the ports.
- Thoroughly clean all pipes and fittings before installing them.
- **Minimum distance to the tank bottom 120 mm**
- Lay the leakage line so that the pump can **not** drain!
- Do **not** pipe a pump **without** controller!
- Leakage and return flow fluid must **under no circumstances** be directly re-aspired!

### Piping suggestions (nominal dimensions in mm)

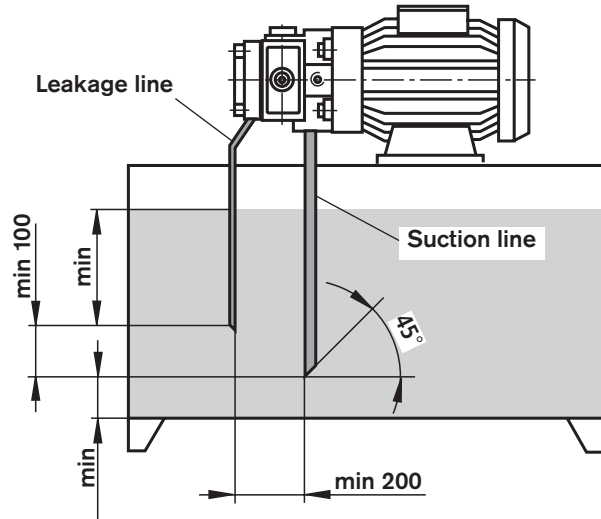

### Filters

- Whenever possible, use return flow or pressure filters. (Suction filters only in conjunction with underpressure switch / clogging indicator)

### Hydraulic fluid

- Please observe our regulations according to data sheet RE 07075.
- We recommend the use of brand name hydraulic fluids.
- Different hydraulic fluid types must not be mixed, since this can result in decomposition and a deterioration of the lubricating properties. Observe the manufacturer's information!
- The fluid must be changed at regular intervals according to the operating conditions. In this context, the fluid tank must be cleaned from residues.